



CUTWATER

CUTWATER 26/28
OWNERS MANUAL



TABLE OF CONTENTS

| | |
|------------------------------------------------------------------|----|
| Table Of Contents | 2 |
| Congratulations | 3 |
| Safety | 3 |
| Symbol Glossary | 4 |
| Specifications (<i>Subject To Change Without Notice</i>) | 5 |
| Equipment Location | 6 |
| Starboard Fittings | 6 |
| Port Fittings | 7 |
| Main Cabin Top Deck Components | 8 |
| Stern Components | 9 |
| Fuse Location & Values | 10 |
| Main Cabin And Cockpit Lights | 12 |
| Battery Compartment | 13 |
| Power Distribution Center | 14 |
| AC Distribution Panel, Rotary Switch & DV Volt Meter | 15 |
| Fuel System, Engine, Generator & Webasto Furnace | 16 |
| Webasto Furnace | 17 |
| Air Conditioning System | 18 |
| Generator | 19 |
| Solar Panel | 20 |
| Shore Power | 21 |
| Closed Engine Cooling System | 22 |
| Sea Strainer System | 23 |
| Raw Water Wash Down | 24 |
| Fresh Water Plumbing System | 25 |
| Shower Sump | 26 |
| Bilge Pump System | 27 |
| Waste System | 28 |
| Mast Set Up And Takedown | 29 |
| Cutwater 28 Wiring Schematic (Acc. 1) | 30 |
| Cutwater 28 Wiring Schematic (Acc. 2) | 31 |
| Cutwater 28 Wiring Schematic (Acc. 3) | 32 |
| Cutwater 28 Wiring Schematic (Lighting) | 33 |
| Cutwater 28 Wiring Schematic (P.D.P.) | 34 |
| Cutwater 26 Wiring Schematic (Acc. 1) | 35 |
| Cutwater 26 Wiring Schematic (Acc. 2) | 36 |
| Cutwater 26 Wiring Schematic (Acc. 3) | 37 |
| Cutwater 26 Wiring Schematic (Lighting) | 38 |
| Cutwater 26 Wiring Schematic (P.D.P.) | 39 |
| Working Deck | 40 |
| Care And Maintenance | 41 |
| Example Of A Preparation For The Road Checklist | 41 |
| Example Of A Spring Pre-Launch Checklist | 42 |
| Example Of Winter Storage Checklist | 43 |
| Reference Material | 44 |
| Contacts | 45 |

CONGRATULATIONS

The Cutwater family has a passion for boating. We are committed to continuous process improvement in all areas that affect our customer's satisfaction with our products and providing great customer service.

SAFETY

Safety is always a concern at Cutwater. Please read all manuals to insure that equipment is used in a safe manner. We highly recommend attendance in a Coast Guard approved boating safety course. Such courses are available from the Coast Guard directly or from boating organizations. Owners should have annual inspections to ensure that all safety equipment is current.

SYMBOL GLOSSARY



Attention! – Important Operating or Maintenance Instructions



Attention! – Electrical Shock Hazard

Fresh Water

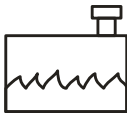

Black Water



Fuel

Standard Equipment



Optional Equipment



Hints

SPECIFICATIONS

C28

| | | |
|--------------------------------------------|------------------------|----------|
| LOA molded | 28' – 4" | 8.63 m |
| LOA rigged (with swim & pulpit) | 32' – 4" | 9.85 m |
| LOA including trailer | 37' – 5" | 11.4 m |
| Height on trailer (with folded mast) | 12' – 9" | 3.9 m |
| Bridge clearance (with folded mast) | 9' – 1" | 2.76 m |
| Beam | 8' 6" | 2.59 m |
| Draft | 28" | .71 m |
| Fuel capacity | 100 U.S. Gal | 378.5 L |
| Water capacity | 40 U.S. Gal | 151.4 L |
| Holding tank capacity | 30 U.S. Gal | 113.6 L |
| Weight (Dry) | 8,000 lbs | 3,629 kg |
| Engine | Volvo D4 260 HP Diesel | |

C26

| | | |
|--------------------------------------------|------------------------|----------|
| LOA molded | 26' – 1" | 7.95 m |
| LOA rigged (with swim & pulpit) | 30' – 4" | 9.25 m |
| LOA including trailer | 35' – 5" | 10.8 m |
| Height on trailer (with folded mast) | 12' – 9" | 3.9 m |
| Bridge clearance (with folded mast) | 9' – 1" | 2.76 m |
| Beam | 8' 6" | 2.59 m |
| Draft | 28" | .71 m |
| Fuel capacity | 80 U.S. Gal | 302.8 L |
| Water capacity | 40 U.S. Gal | 151.4 L |
| Holding tank capacity | 30 U.S. Gal | 113.6 L |
| Weight (Dry) | 6,750 lbs | 3,062 kg |
| Engine | Volvo D3 220 HP Diesel | |

(Subject to Change Without Notice)

EQUIPMENT LOCATION

STARBOARD FITTINGS

STE

1 2 3 4 5 6 (C28 only) 7 8 9



Keep all vents, drains and exhausts clear of any obstructions to ensure proper performance of each system.

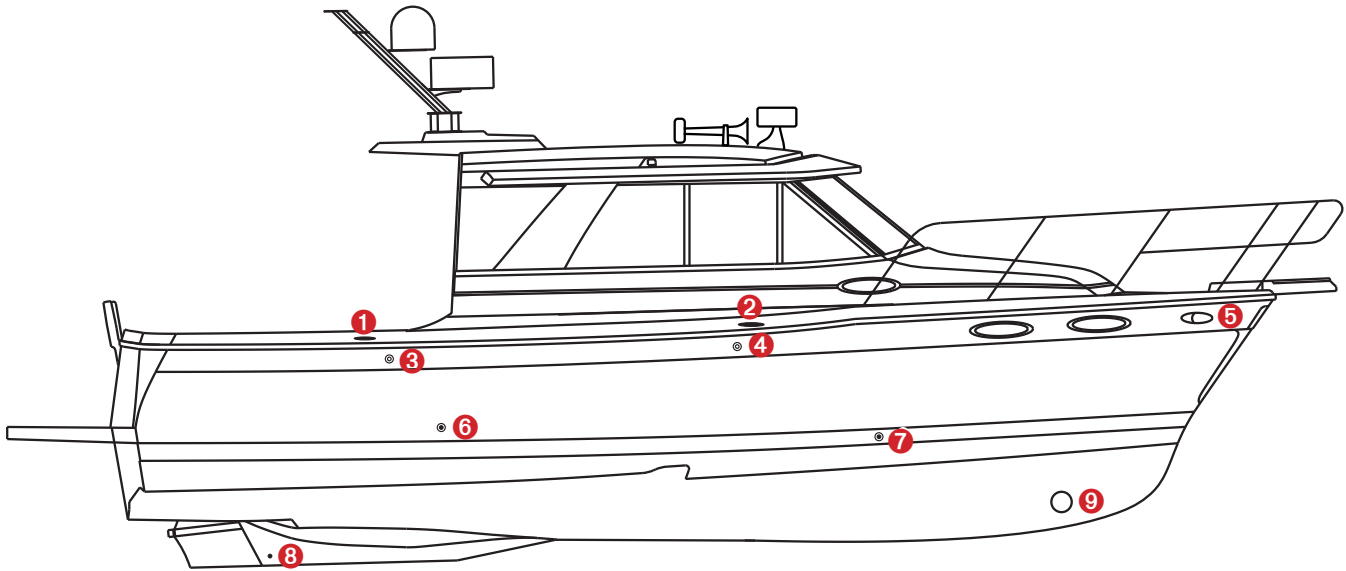

- | | |
|--------------------|-----------------------------|
| 1 Diesel Fill | 6 Aft Sink Drain (C28 only) |
| 2 Fresh Water Fill | 7 Head Sink Drain |
| 3 Fuel Vent | 8 Keel Drain Plug |
| 4 Water Vent | 9 Bow Thruster |
| 5 Docking Lights | |

STE

1 2 3 4 5 6 10 11 12 13 14

OPT

7 8 9



Keep all vents, drains and exhausts clear of any obstructions to ensure proper performance of each system.

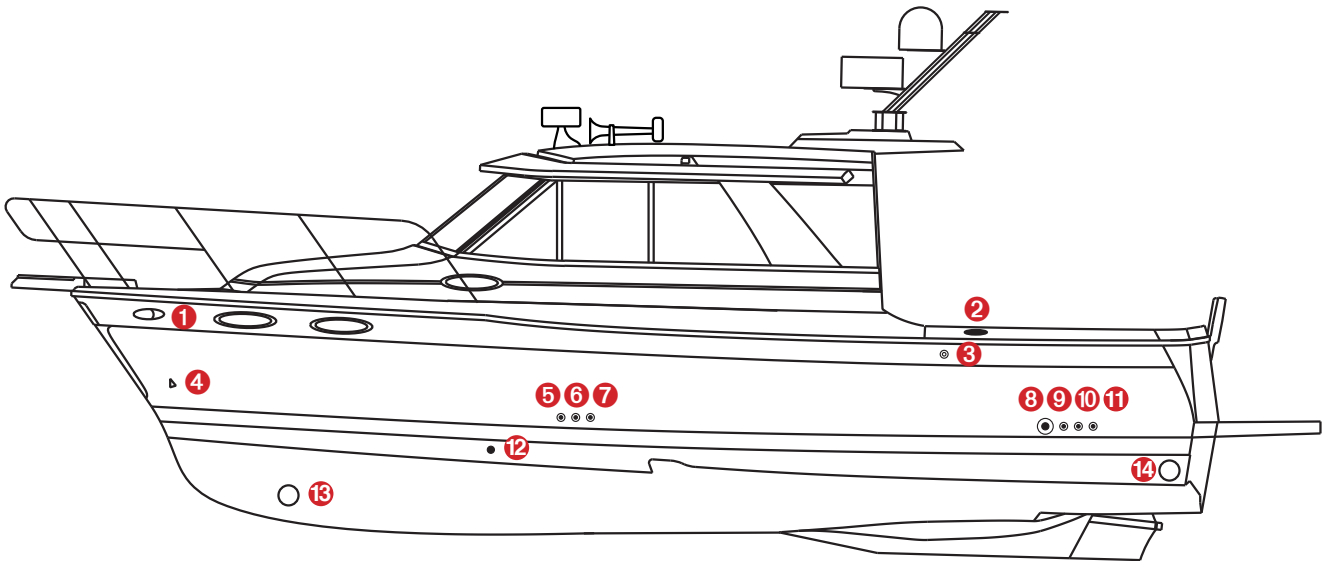

- 1 Docking Lights
- 2 Waste Pumpout
- 3 Waste Vent
- 4 Anchor Locker Drain
- 5 Shower Sump
- 6 Air Conditioner Drain
- 7 Cabin Sink Drain

- 8 Generator Exhaust
- 9 Forward Bilge Drain
- 10 Aft Bilge Drain
- 11 Macerator
- 12 Forward Sink Drain
- 13 Bow Thruster
- 14 Engine Exhaust

MAIN CABIN TOP DECK COMPONENTS

STE

1 2 3 6

OPT

4 5

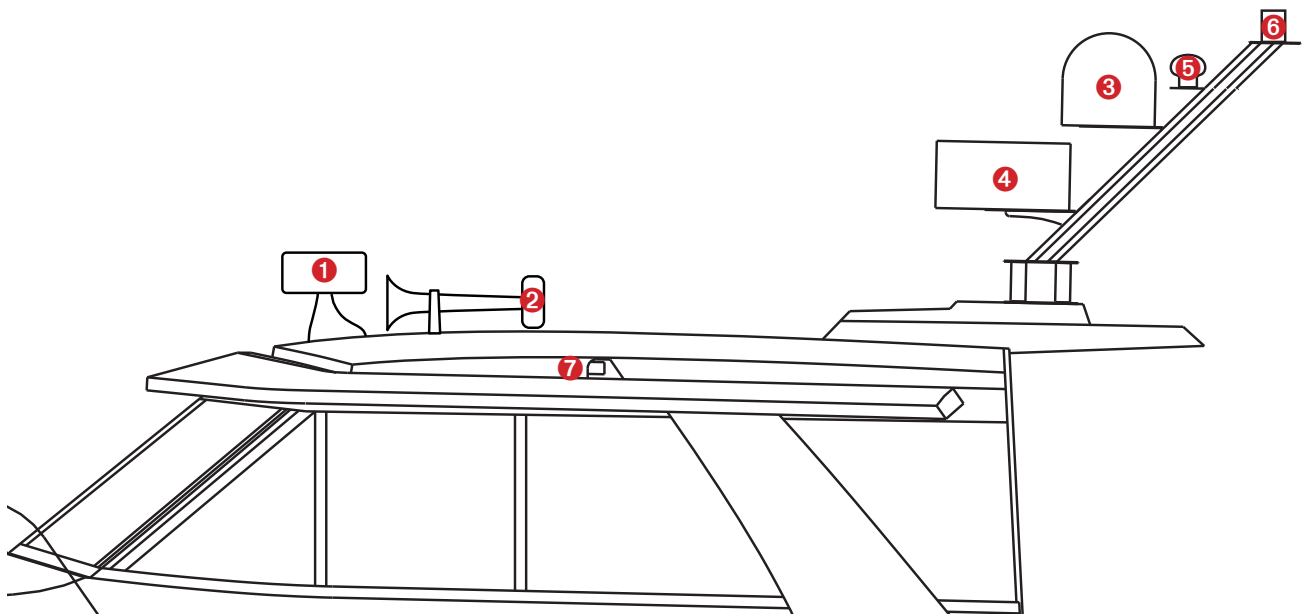

- ① Searchlight
- ② Horn
- ③ Digital TV Antennae (satellite ready - not included)
- ④ Radar
- ⑤ GPS
- ⑥ Anchor Light
- ⑦ Port Navigation Light

STERN COMPONENTS

STE

1 2 3 4 5 7 8 9 10 11 12

OPT

6

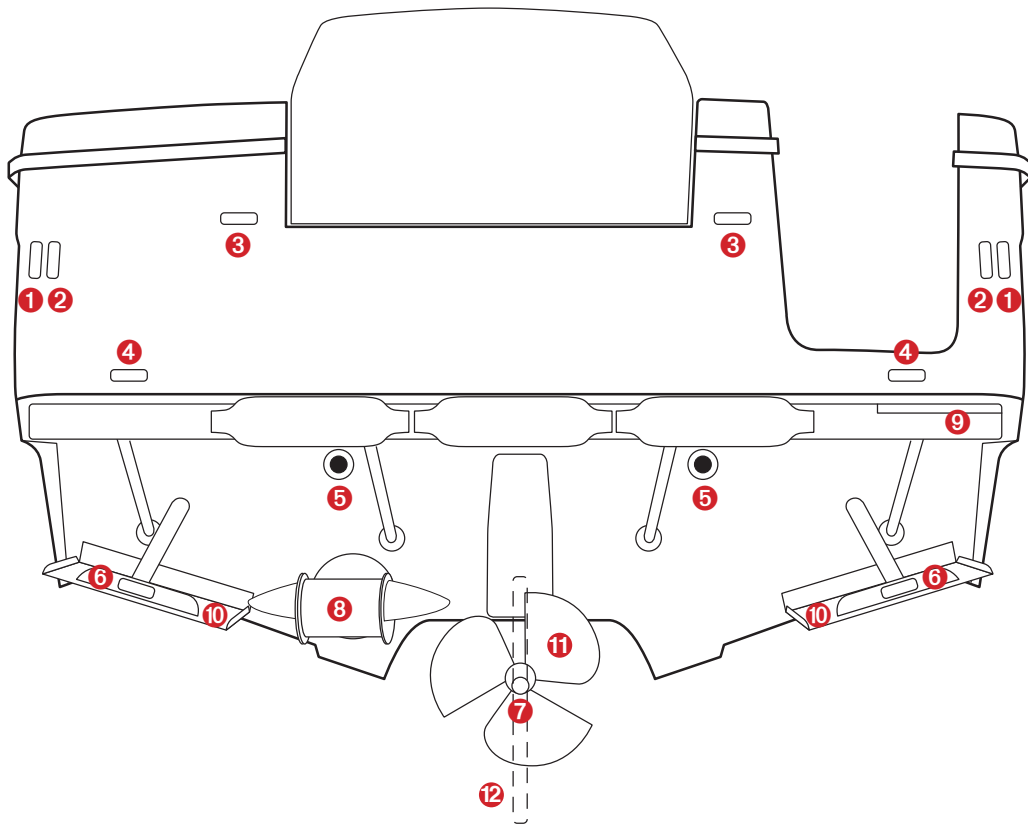

- | | |
|---------------------|------------------------------------|
| 1 Brake Lights | 7 Prop Zinc |
| 2 Backup Lights | 8 Stern Thruster |
| 3 Running Lights | 9 Swim Platform Retractable Ladder |
| 4 Courtesy Lights | 10 Trim Tabs |
| 5 Cockpit Drains | 11 Prop |
| 6 Underwater Lights | 12 Rudder |

FUSE LOCATION & VALUES

STE

The dash fuse blocks are located behind the hinged mirror located inside of the bathroom. Fuses are automotive blade type and all values are shown in amps.

Dash Fuse Block #1

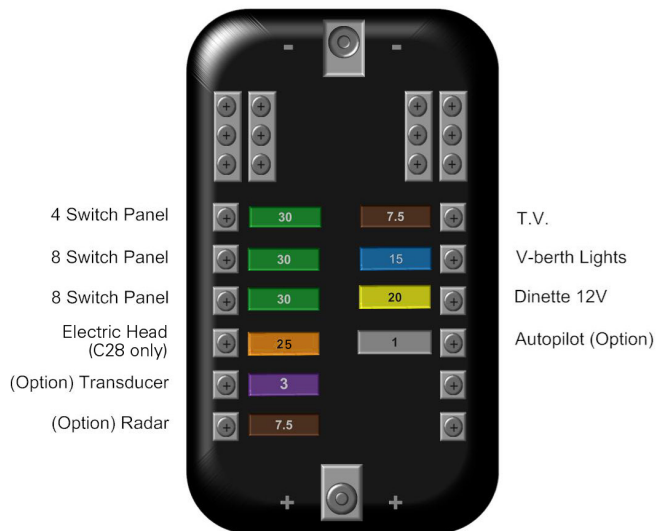

Dash Fuse Block #2

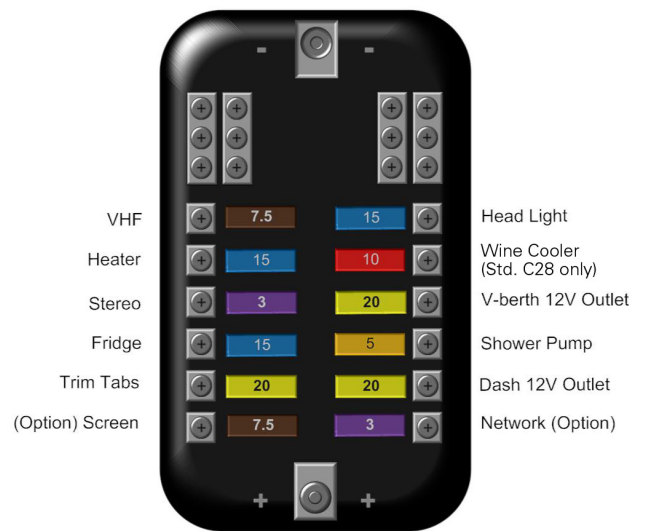

FUSE LOCATIONS AND VALUES CONTINUED

STE

These five blocks and fuses are located behind the carpeted panel that is removable on the aft wall just below the Power Distribution Panel.



The bilge pumps operate automatically with electronic float switches when all switches and breakers are in the OFF position.

However, the BILGE PUMP and BILGE PUMP2 will run continuously once their switches are placed in the on position. Monitor the outflow accordingly. Do not run when dry.

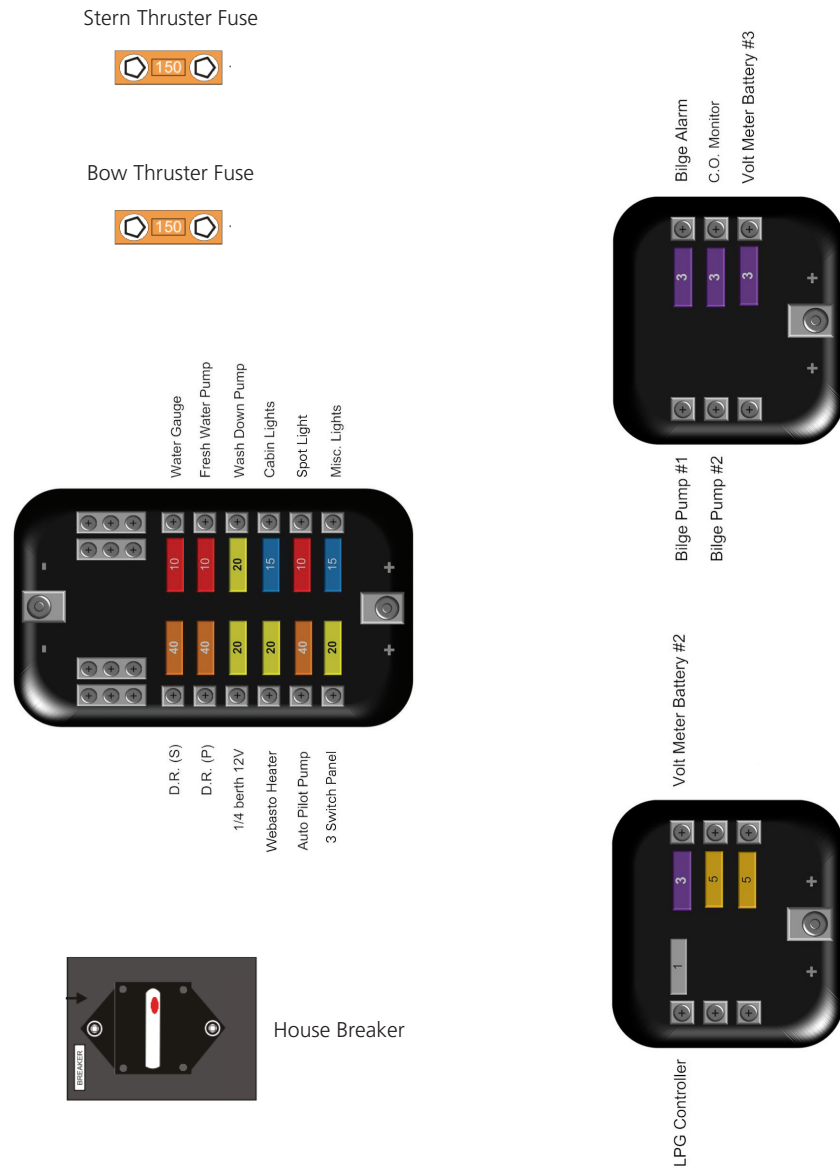

MAIN CABIN AND COCKPIT LIGHTS

STE

| | Courtesy Light Switch | V-Berth Light Switch | Cabin Light Switch | Head Light Switch | Chart Light Switch |
|----------------------|-----------------------|----------------------|--------------------|-------------------|--------------------|
| 1 Courtesy Lights | ✓ | | | | |
| 2 Deck Aft Lights | | | ✓ | | |
| 3 Chart Lights | | | | | ✓ |
| 4 Cabin Lights | | | ✓ | | |
| 5 V-Berth Lights | | ✓ | | | |
| 6 V-Berth Bed Lights | | ✓ | | | |
| 7 Head Light | | | | ✓ | |

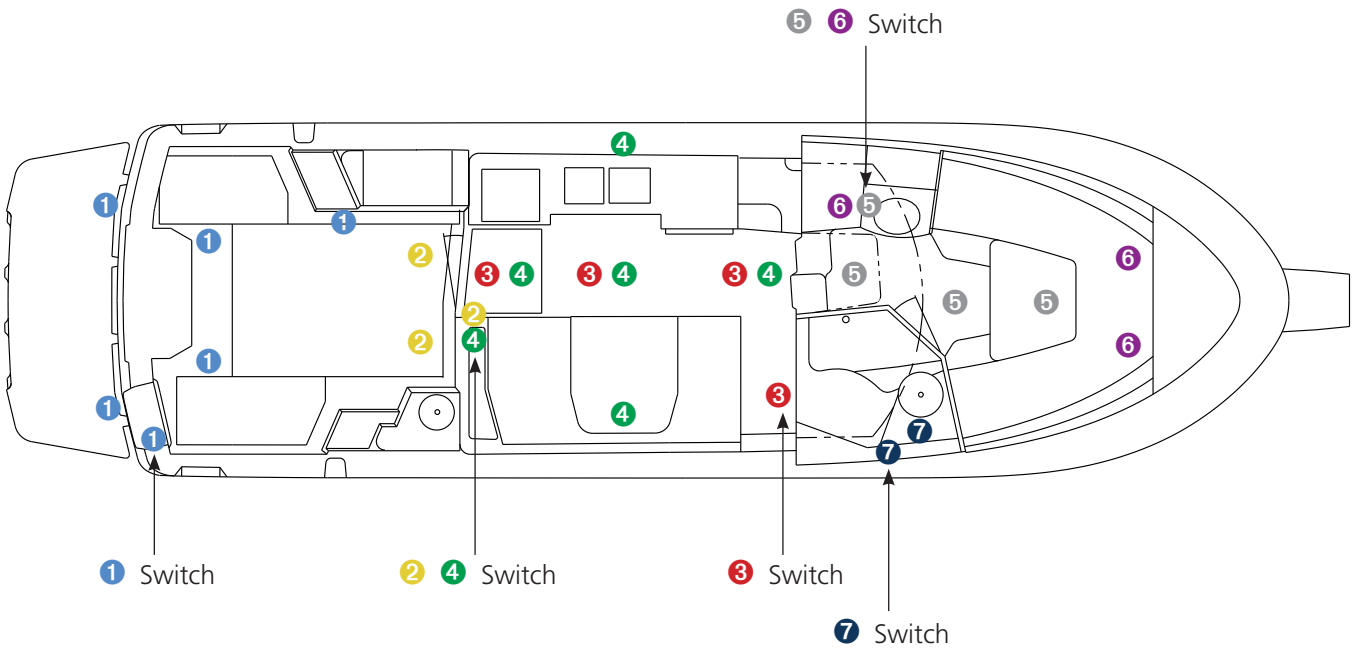

BATTERY COMPARTMENT

STE

House Batteries, Engine Battery, Thruster Battery, Inverter/Charger, Engine ECM, Inverter Fuse (150 AMP), Inverter/Charger Cutoff Switch

Non-Generator

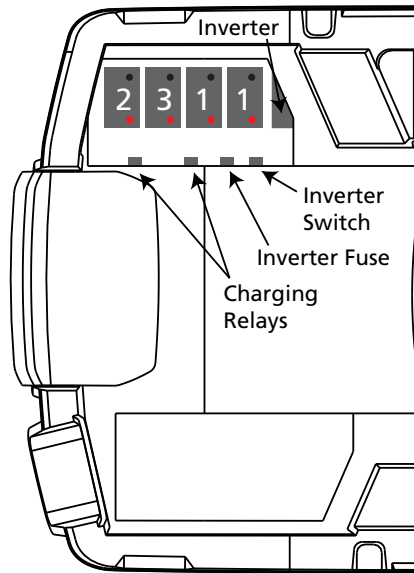

Generator

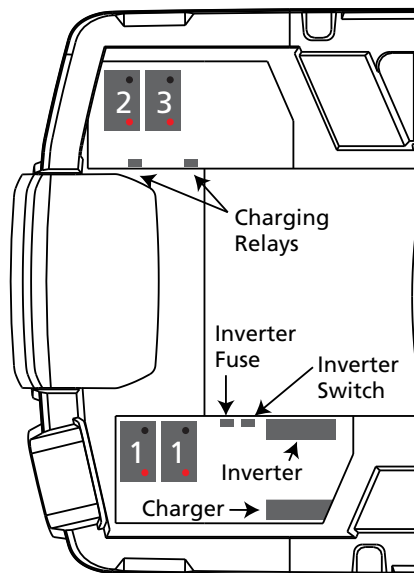

| Batteries |
|--------------|
| 1 = House |
| 2 = Engine |
| 3 = Thruster |

POWER DISTRIBUTION CENTER

STE

Located under aft dinette seat.
House, Engine, Thruster crossover switch

OPT

Generator Panel, Solar Display, Diesel Heater Control, Air Conditioning Display



The crossover switch should always remain in the off position. While in the on position, the house and engine batteries will be combined as one.

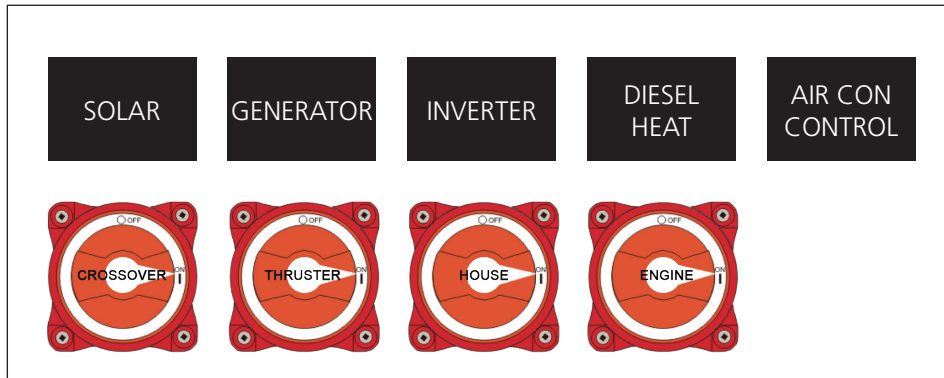

AC DISTRIBUTION PANEL, ROTARY SWITCH & DC VOLT METER

STE

AC Distribution Panel

OPT

AC Rotary Selector Switch. Available with Generator



The AC Rotary Switch Selector Switch will determine which source of incoming 120 Volt power to use for your AC Distribution Panel.

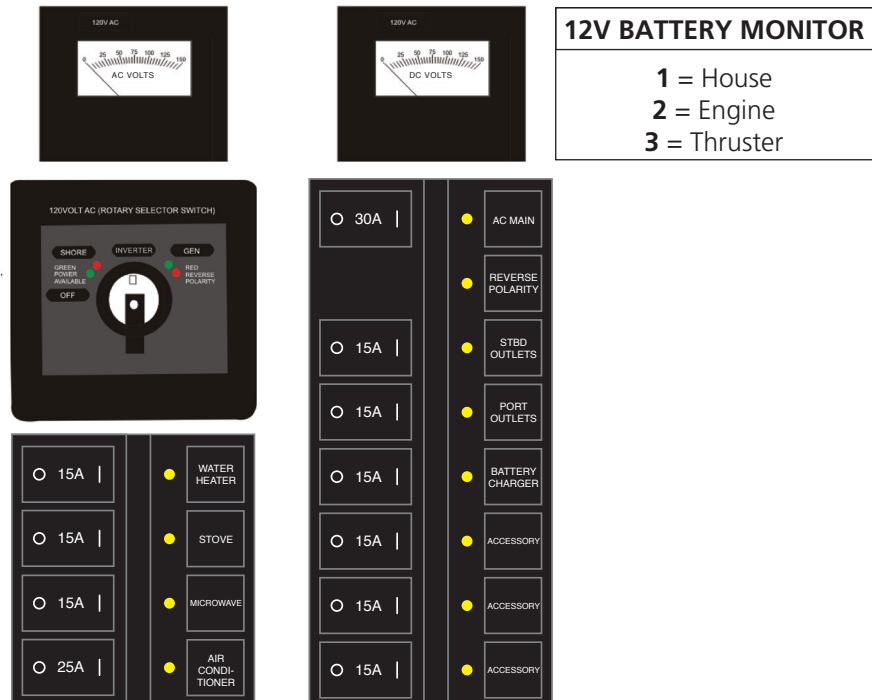

FUEL SYSTEM, ENGINE, GENERATOR & WEBASTO FURNACE

STE

C28 Volvo D4 260 H.P. Diesel
C26 Volvo D3 220 HP Diesel

OPT

Generator 2.7 KW Mase, Webasto Furnace

- There is a secondary on engine fuel filter that is not shown on this drawing. You will be able to find information about this filter in the diesel engine manual supplied with your boat.
- Fuel shutoff and all fuel fittings are located inside the floor hatch as you enter the main cabin.

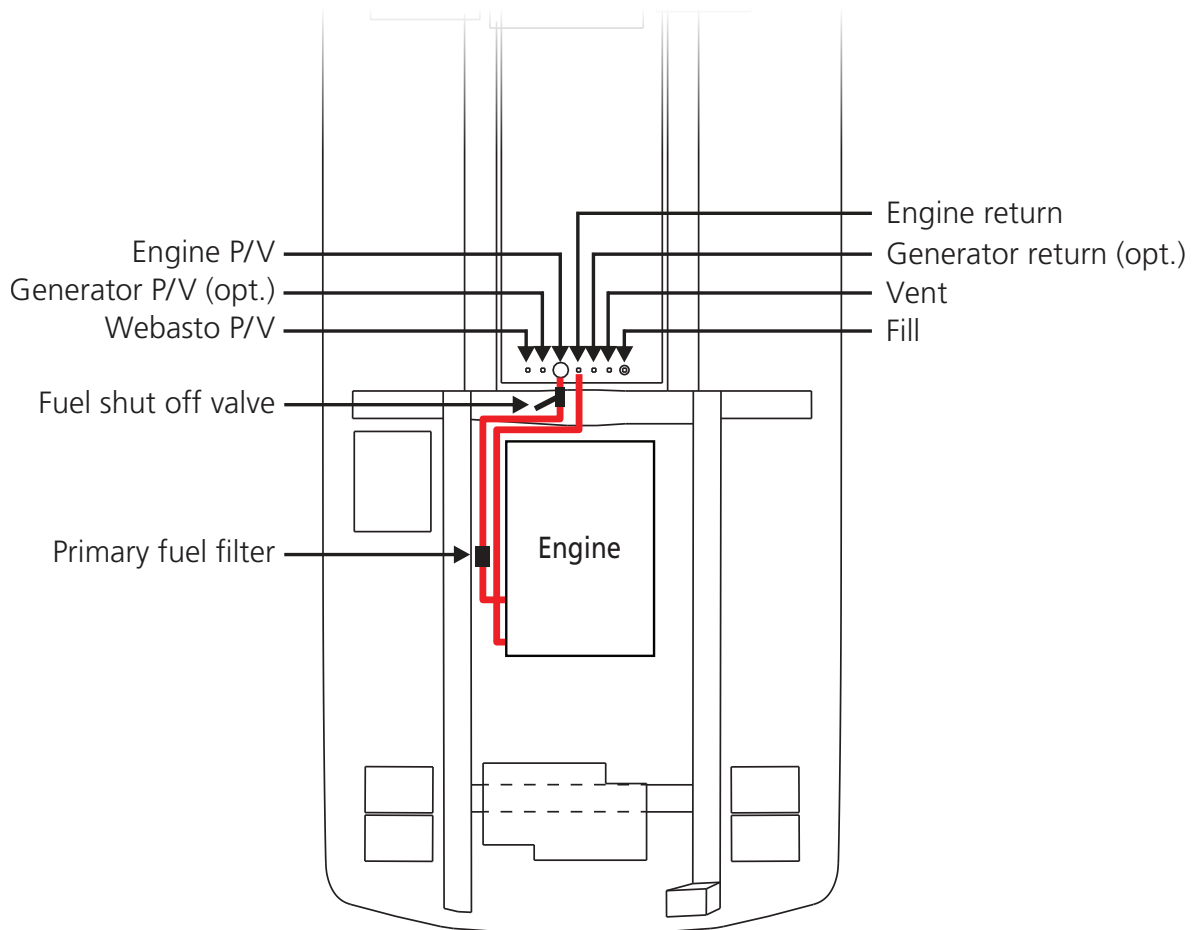

WEBASTO FURNACE

OPT

Webasto furnace & pump are located behind an access panel in the quarter berth. The controller is located at the power distribution panel.

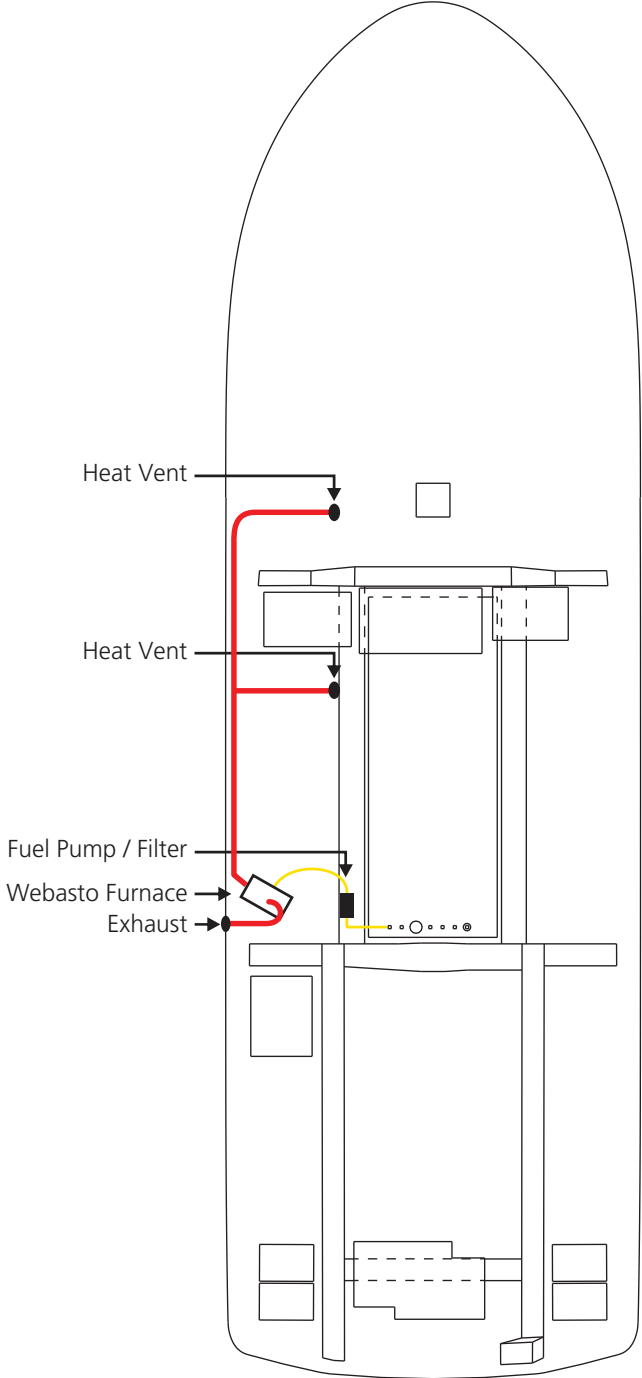

AIR CONDITIONING SYSTEM

OPT

Air Conditioning System

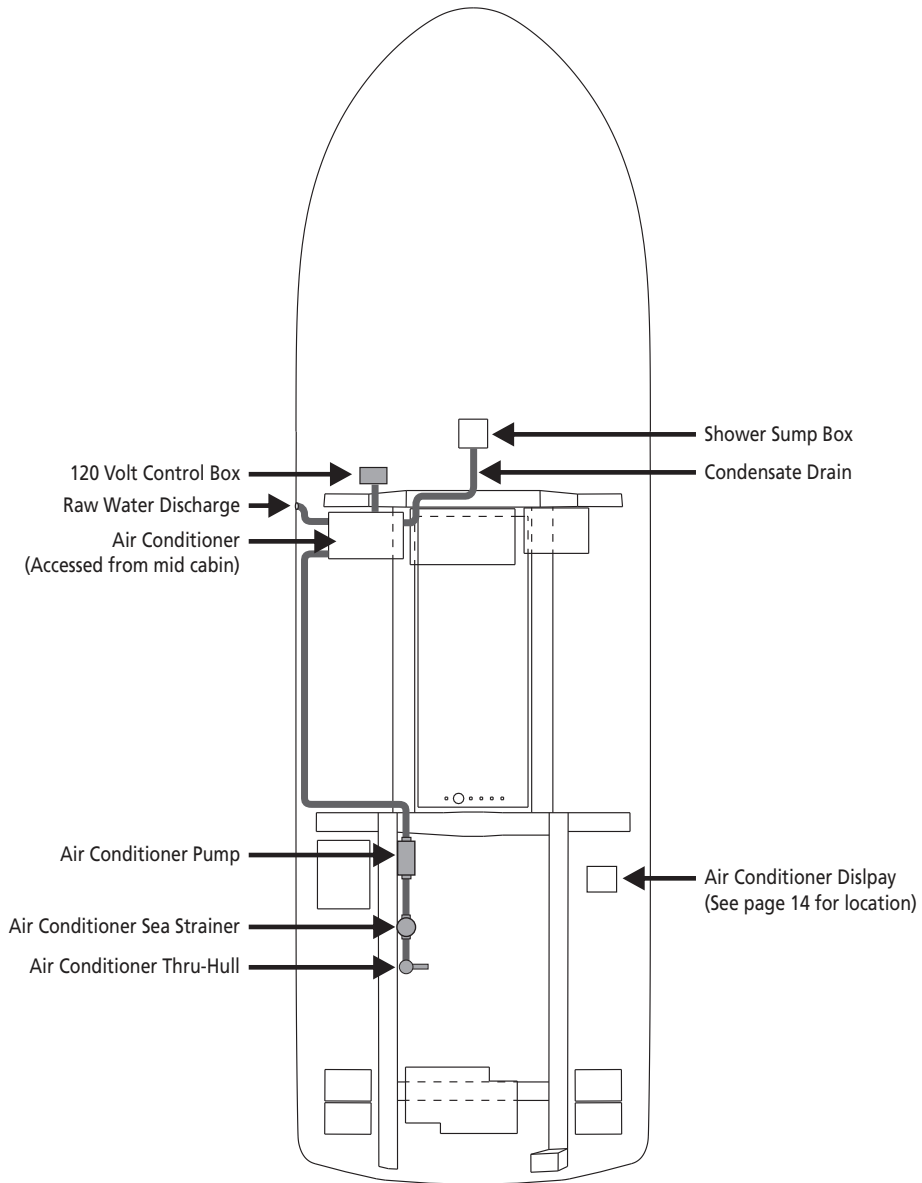

GENERATOR

OPT

Generator 2.7 KW Mase
*Generator will start off of thruster battery #3

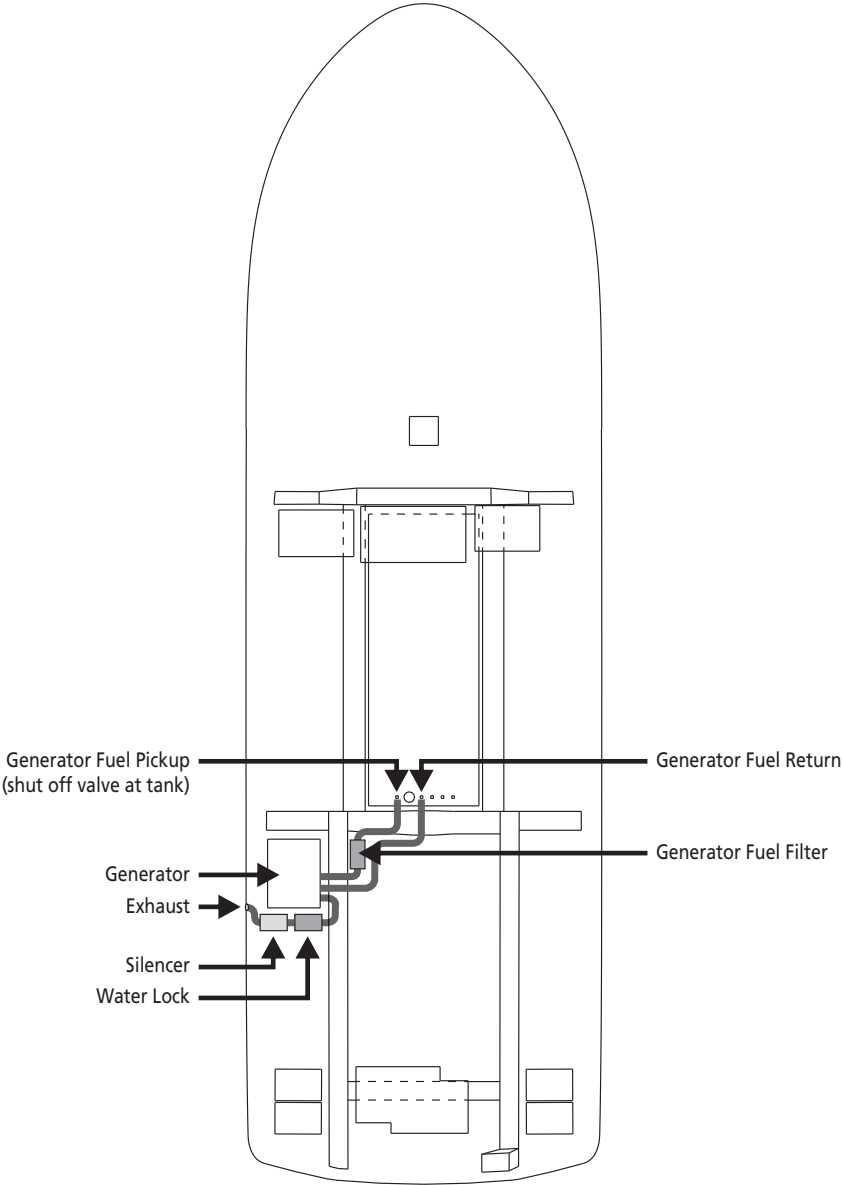

SOLAR PANEL

OPT

Solar panel 140 watt, with control panel

- The solar panel is designed to provide charging to the house & engine batteries. 90% of its charge is dedicated to the house battery and 10% is dedicated to the engine battery.
 - The green light on the solar display indicates proper operation.
 - The solar controller is located behind the Velcro access panel inside the mid cabin at the aft bulkhead.
- * House battery location shown with generator option equipped.

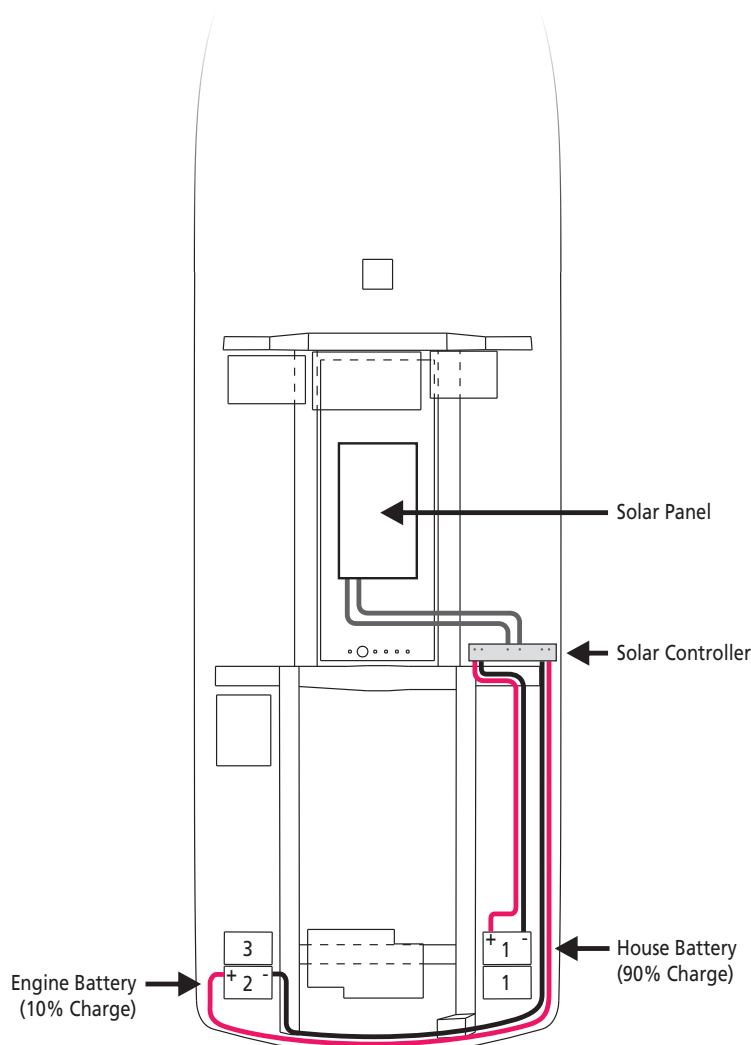

SHORE POWER LAYOUT

STE

Shore Power

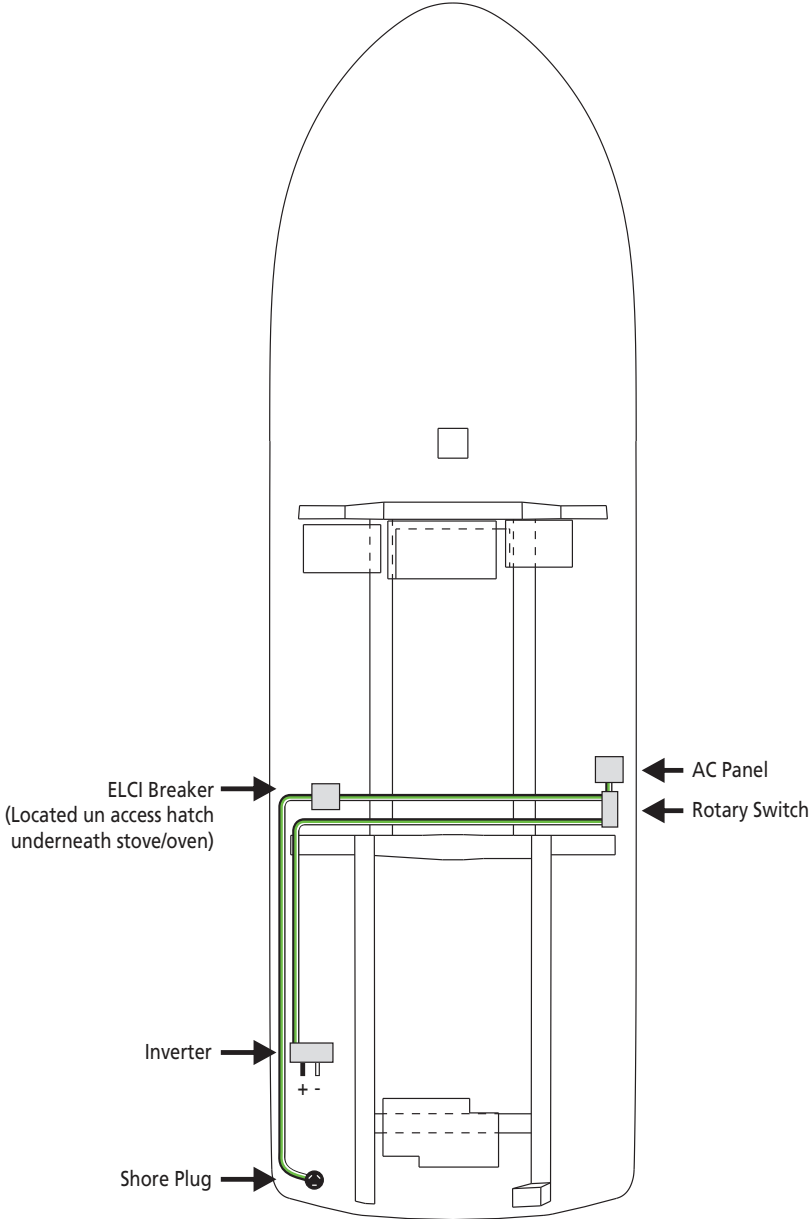

CLOSED ENGINE COOLING SYSTEM

STE

Provides alternate heating system for the Fresh Water Heater and provides primary heating source for the Forced Air Cabin Heater. This system is also designed to provide cooling to the internal components of your engine. Please refer to your engine operations manual for more information.

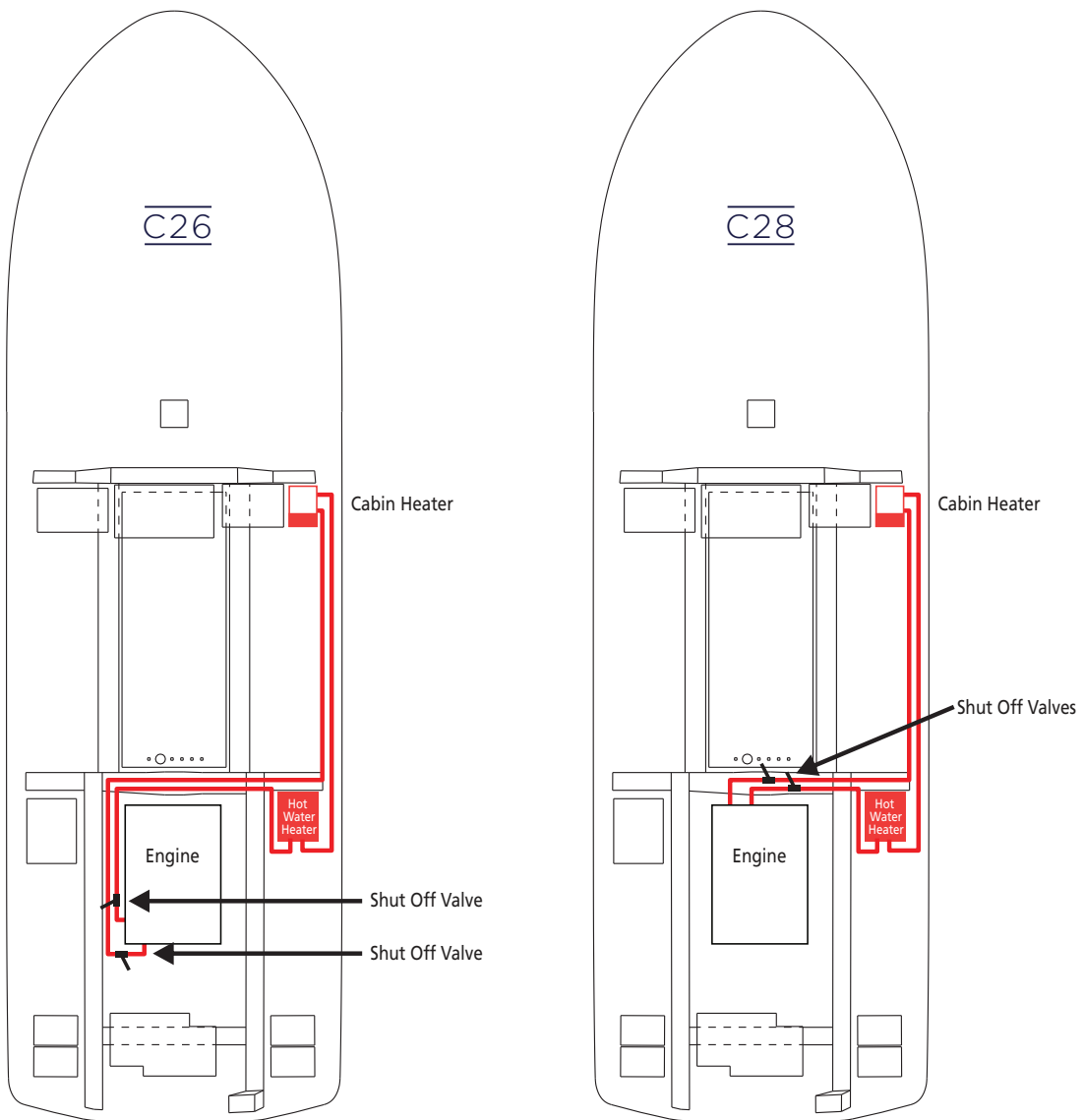

RAW WATER WASH DOWN

STE

Johnson Aqua Jet 5.2 GPM

- The raw water washdown pump and all components shown are accessible from the rear of the engine compartment.

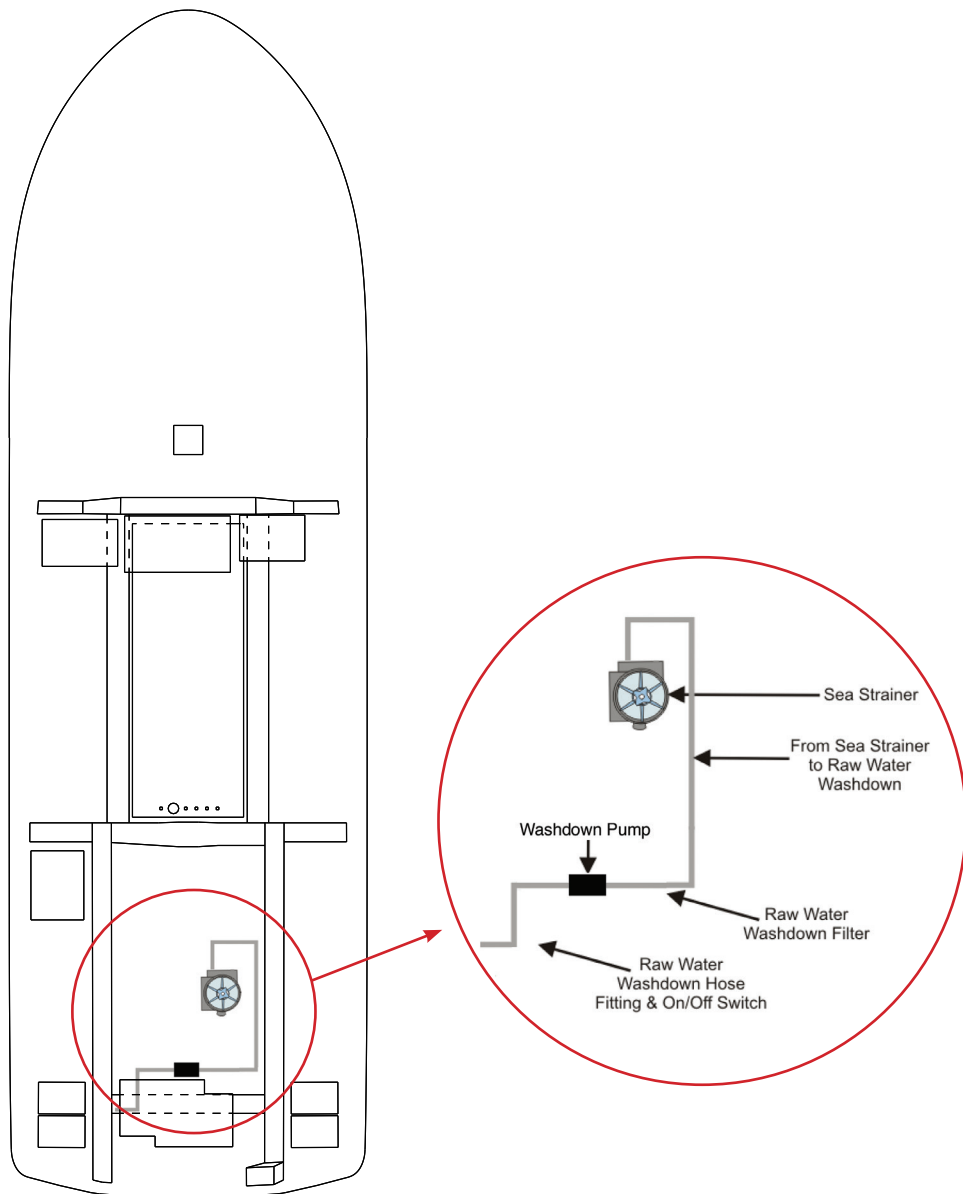

FRESH WATER PLUMBING SYSTEM

STE

40 Gallon Fresh Water Tank, 6 Gallon Hot Water Heater, 4.0 GPM Fresh Water Pump.

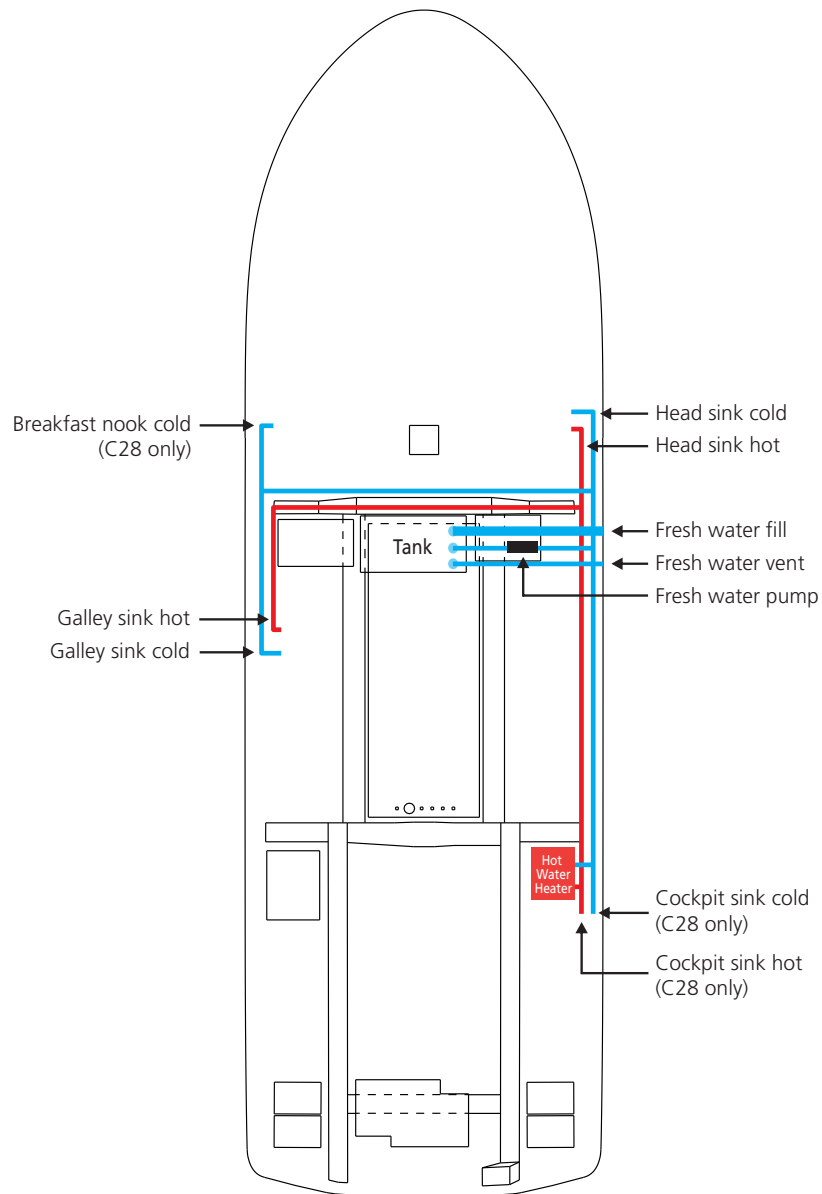

SHOWER SUMP

STE

12V, 500 GPH
(Sump should be inspected for debris on a regular basis if shower is used frequently.)

- The shower sump box is located underneath the teak and holly floor.

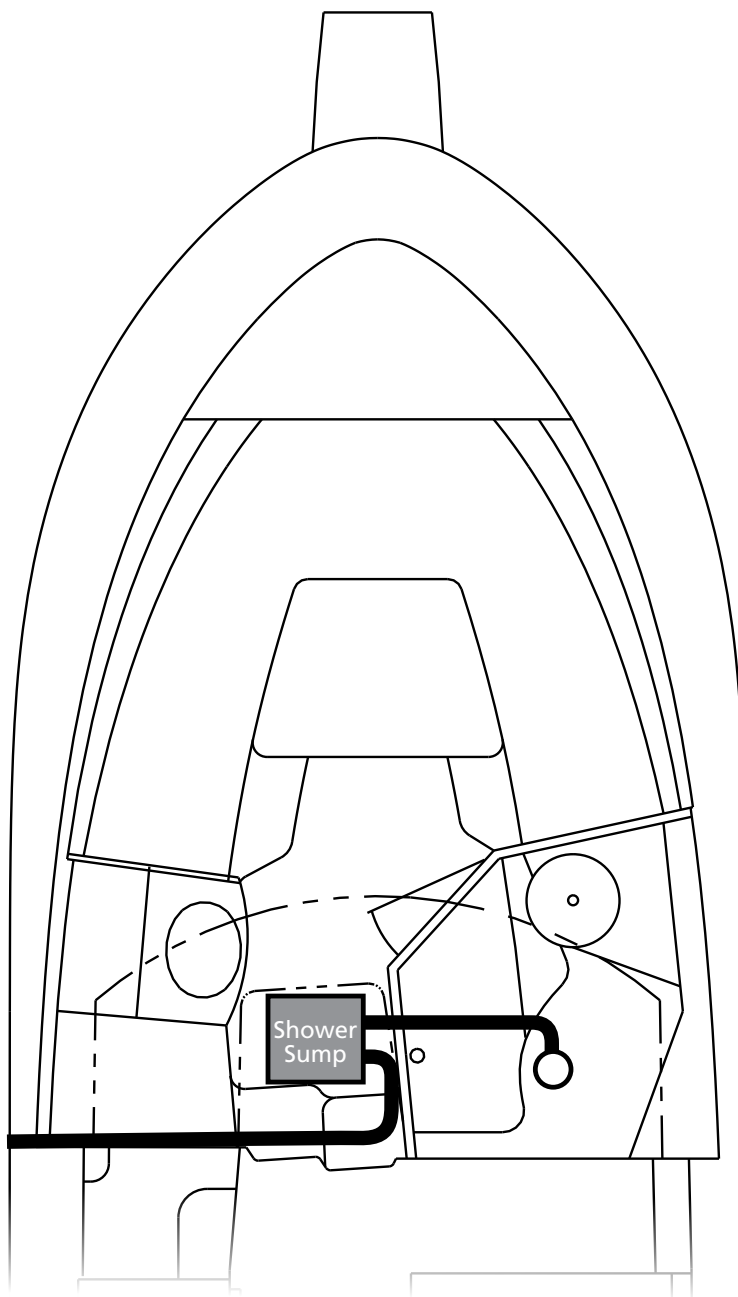

BILGE PUMP SYSTEM

STE

12V 750GPH



The bilge pumps operate automatically with electronic float switches when all switches and breakers are in the OFF position.

However, the BILGE PUMP and BILGE PUMP2 will run continuously once their switches are placed in the on position. Monitor the outflow accordingly. Do not run when dry.

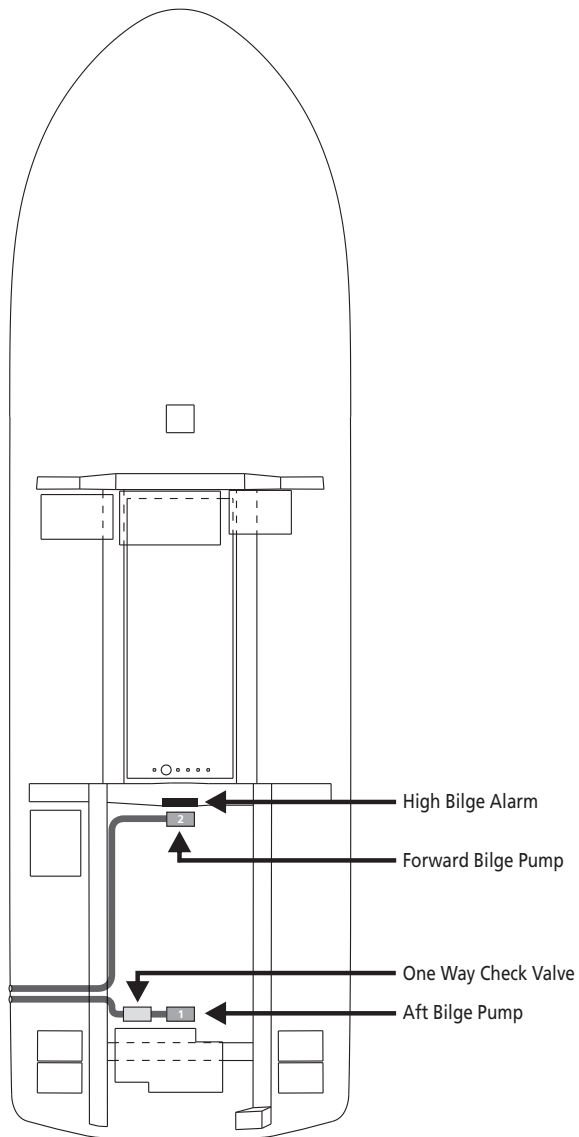

WASTE SYSTEM WITH MACERATOR PUMP

STE



30 Gallon Tank with Macerator Pump Out, Standard Pump Out, and Vent



Waste tank fill level can be checked by lifting the engine access hatch and viewing the translucent waste tank. Pump out can be done with the macerator or standard pump out. The Y-Valve that switches between the two can be accessed through the Engine Hatch, aft of the engine.



Waste tank pump out stations are widely available. Please follow the directions carefully for the pump out equipment you are using to avoid damage to the waste system.



Boat owner is responsible for following all applicable laws when using the macerator system to pump out into the surrounding waters.

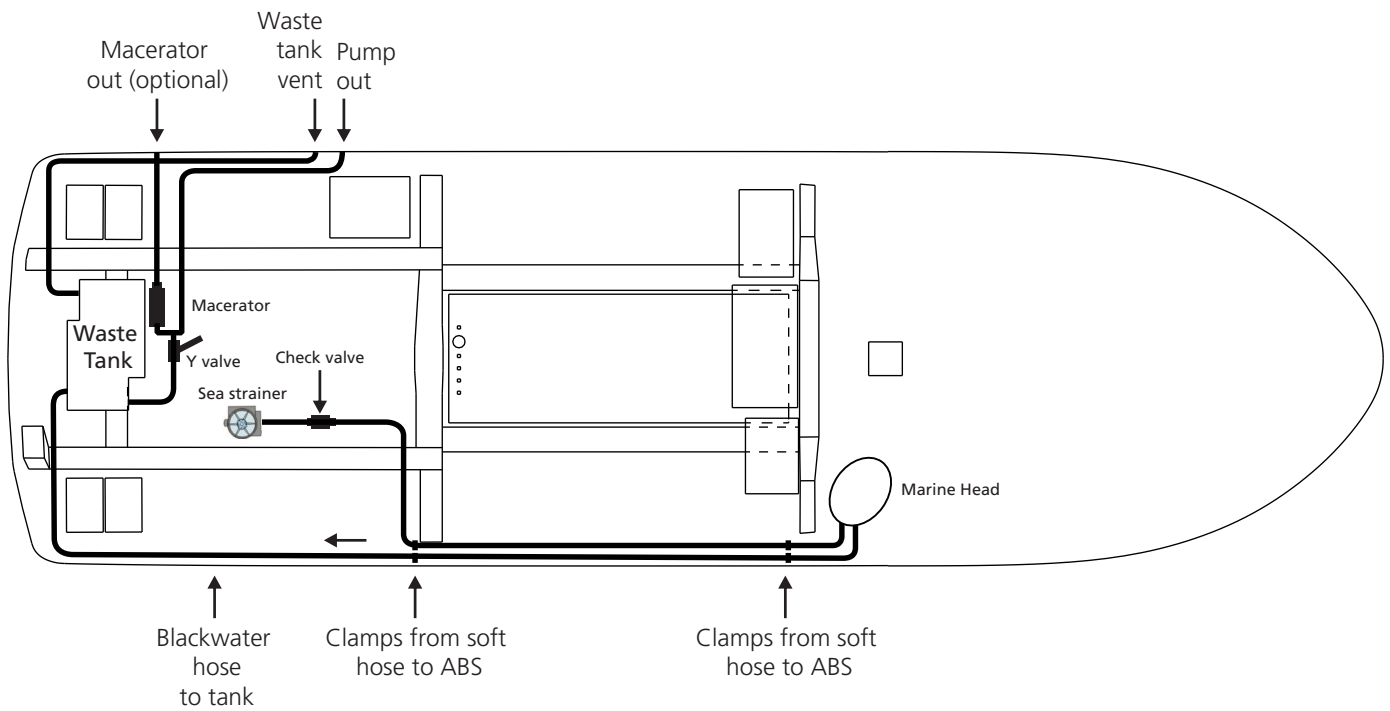

MAST SET UP AND TAKEDOWN

MAST SET UP PROCEDURE

1. Remove the two black plastic wing nuts from the mast base.
2. While supporting the mast, remove the pin in the support bar.
3. Raise the mast to its full extension and ensure that it fits correctly over the mounting studs on the roof mounting plate.
4. Secure the stainless steel retaining bar in the appropriate clip attached next to the v-berth escape hatch.
5. Attach the two black plastic wing nuts to the mounting studs and hand tighten securely.

MAST TAKE DOWN PROCEDURE

1. Remove the two black plastic wing nuts from the mast base mounting studs.
2. Carefully lower the mast onto the stainless steel support bar and attach retaining pin.
3. Attach the black plastic wing nuts back onto the screws on the mast mounting plate and secure them for storage by hand tightening.
4. Recommend securing the mast with a tie down.

CUTWATER 28 WIRING SCHEMATIC (ACC. 1)

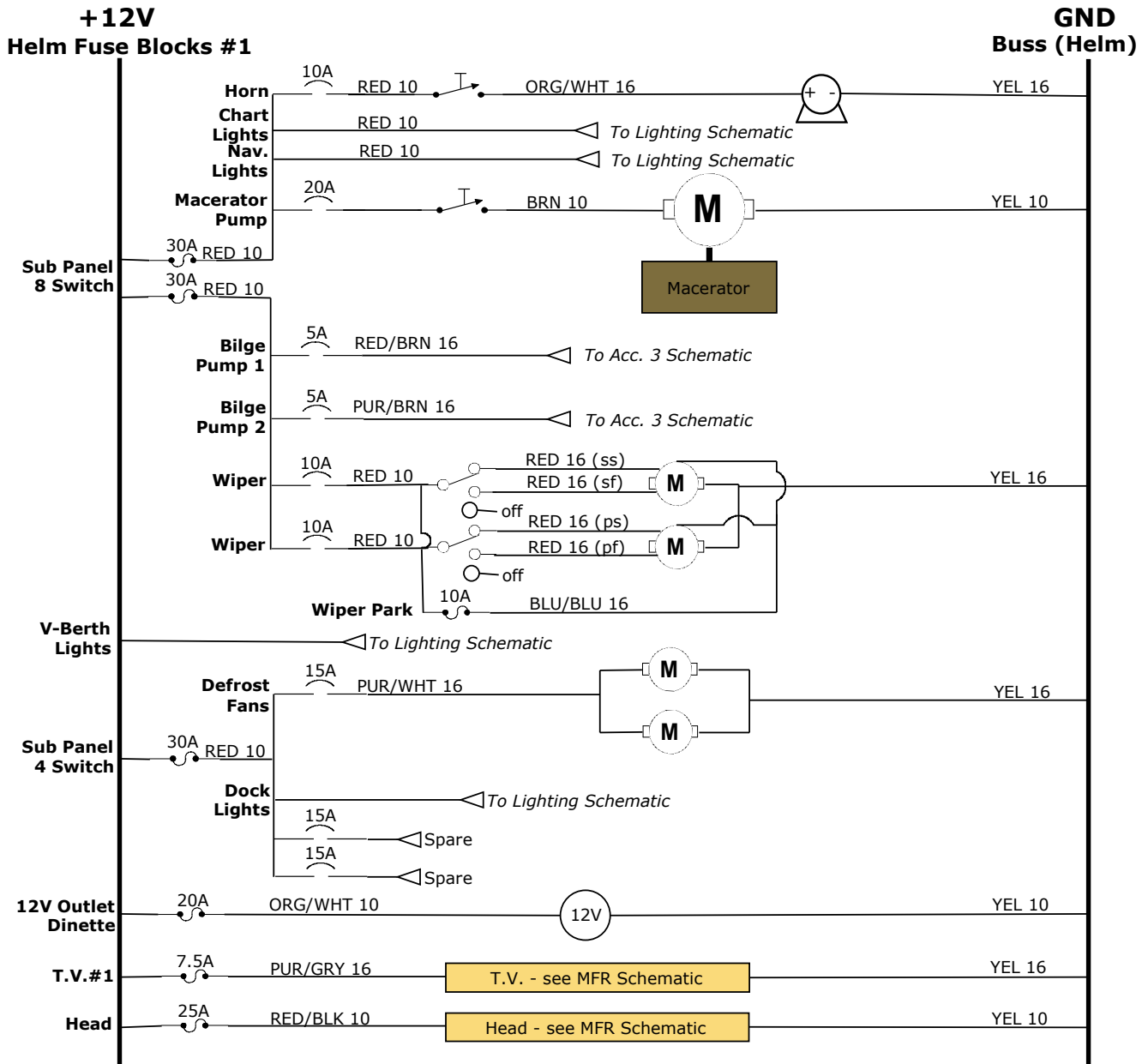

SYMBOL KEY

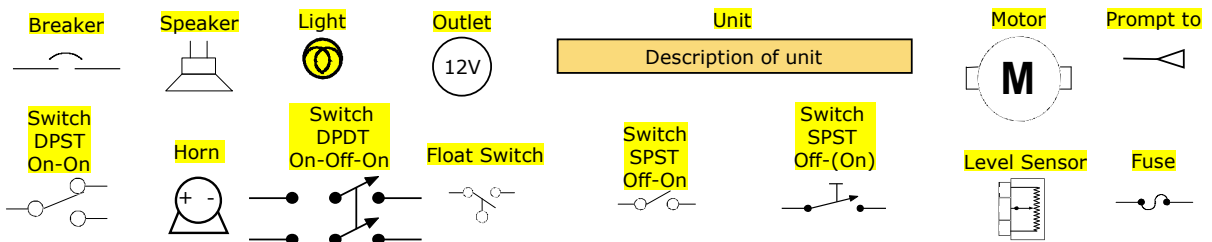

CUTWATER 28 WIRING SCHEMATIC (ACC. 2)

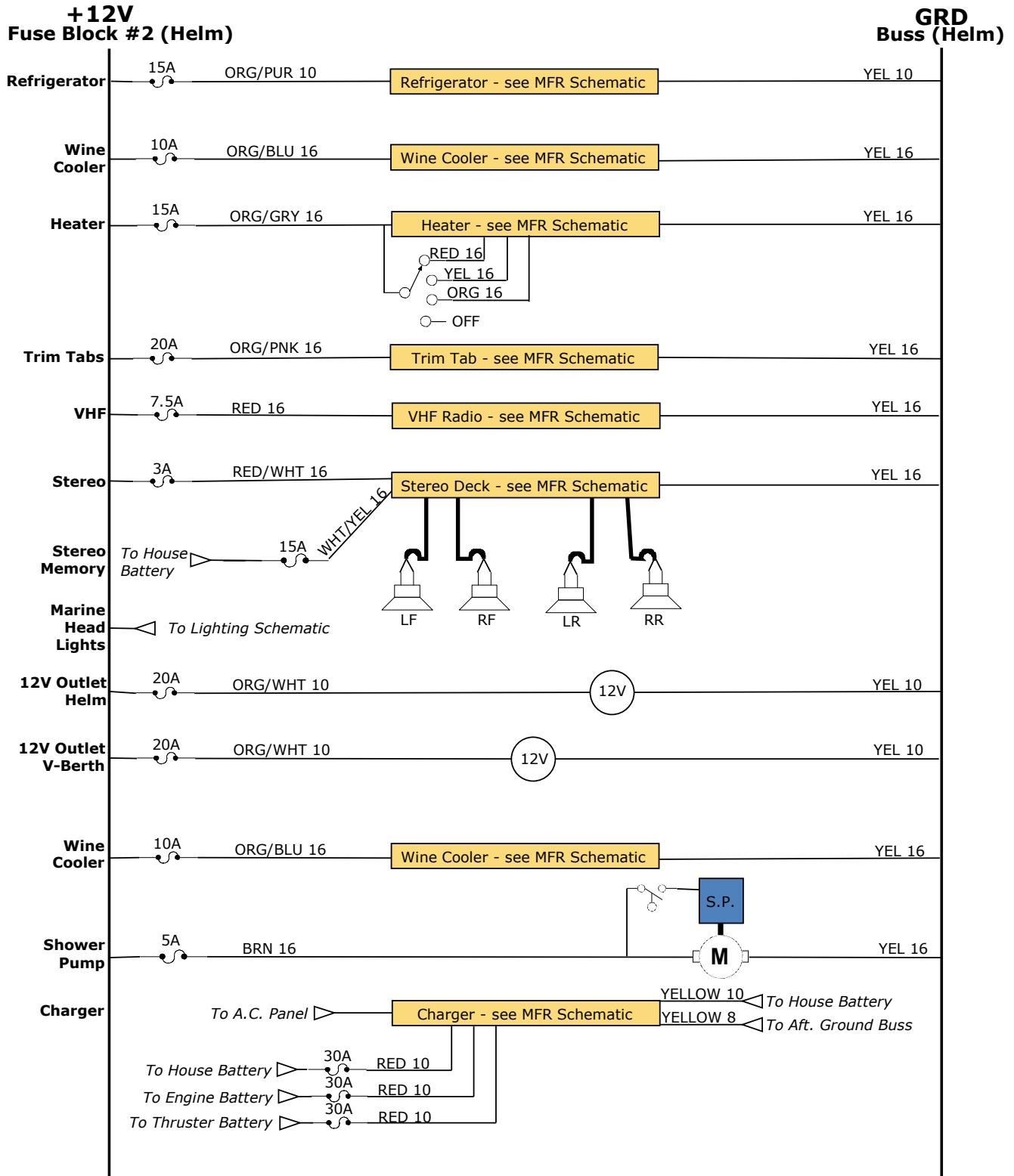

CUTWATER 28 WIRING SCHEMATIC (LIGHTING)

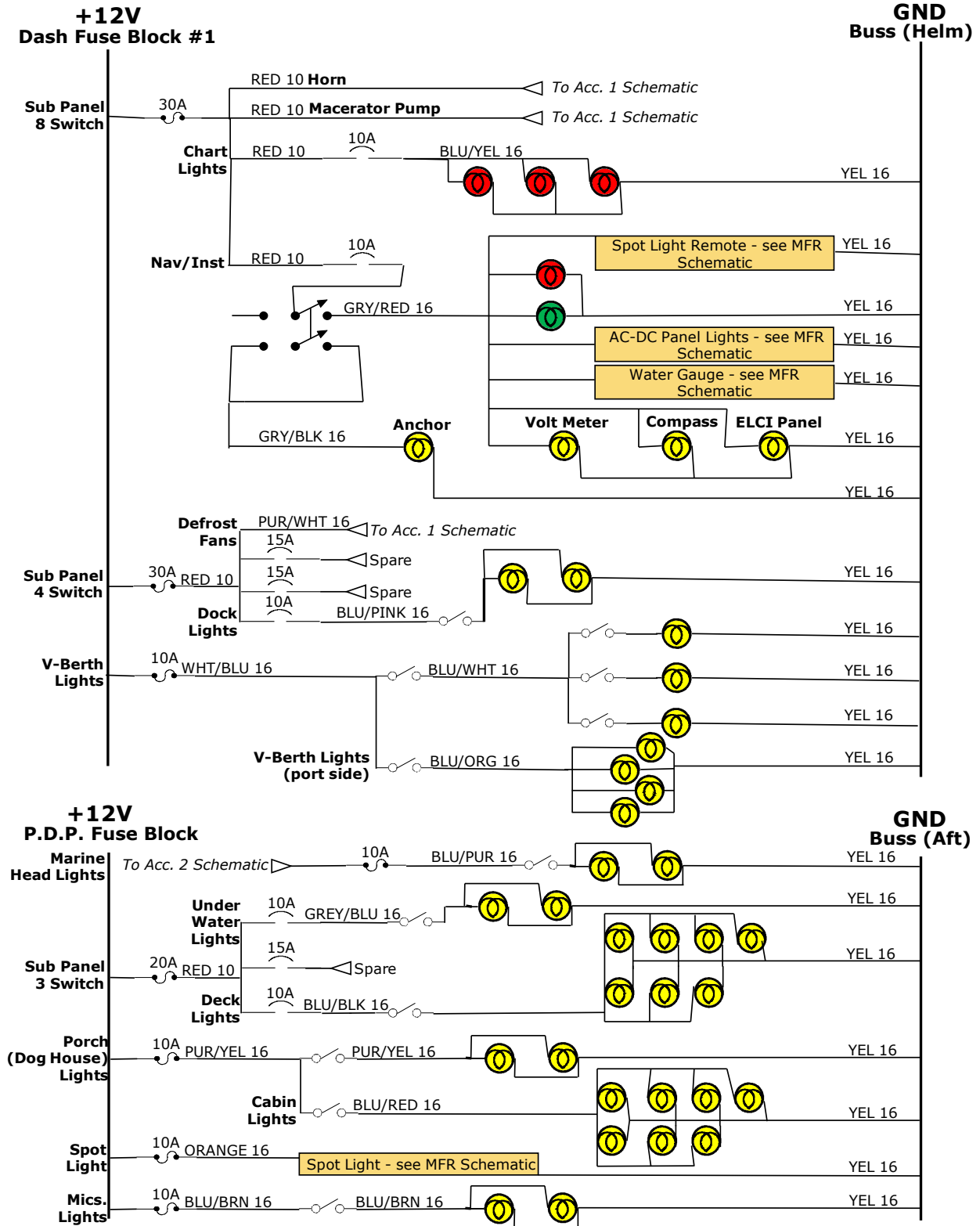

CUTWATER 28 WIRING SCHEMATIC (P.D.P.)

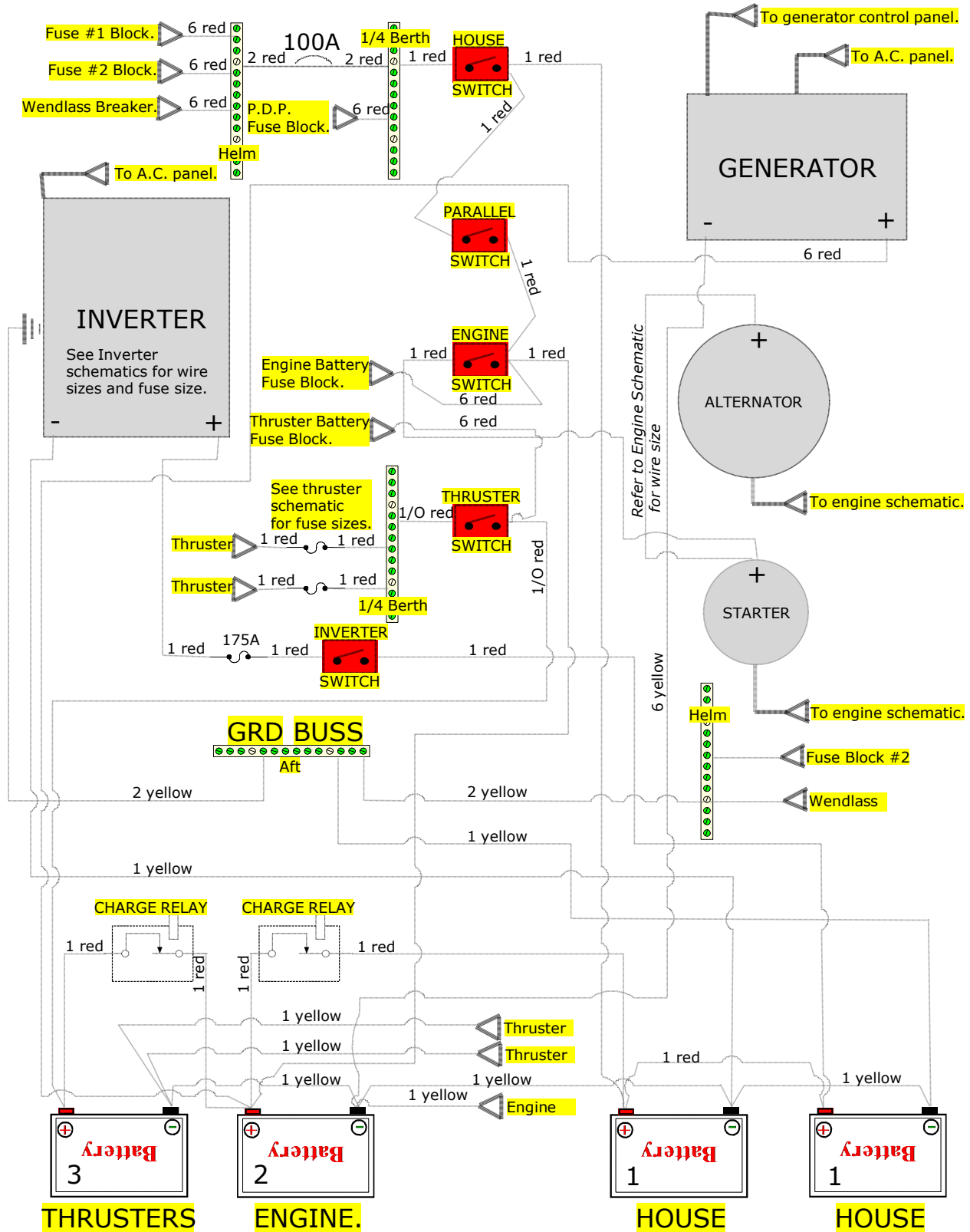

CUTWATER 26 WIRING SCHEMATIC (ACC. 1)

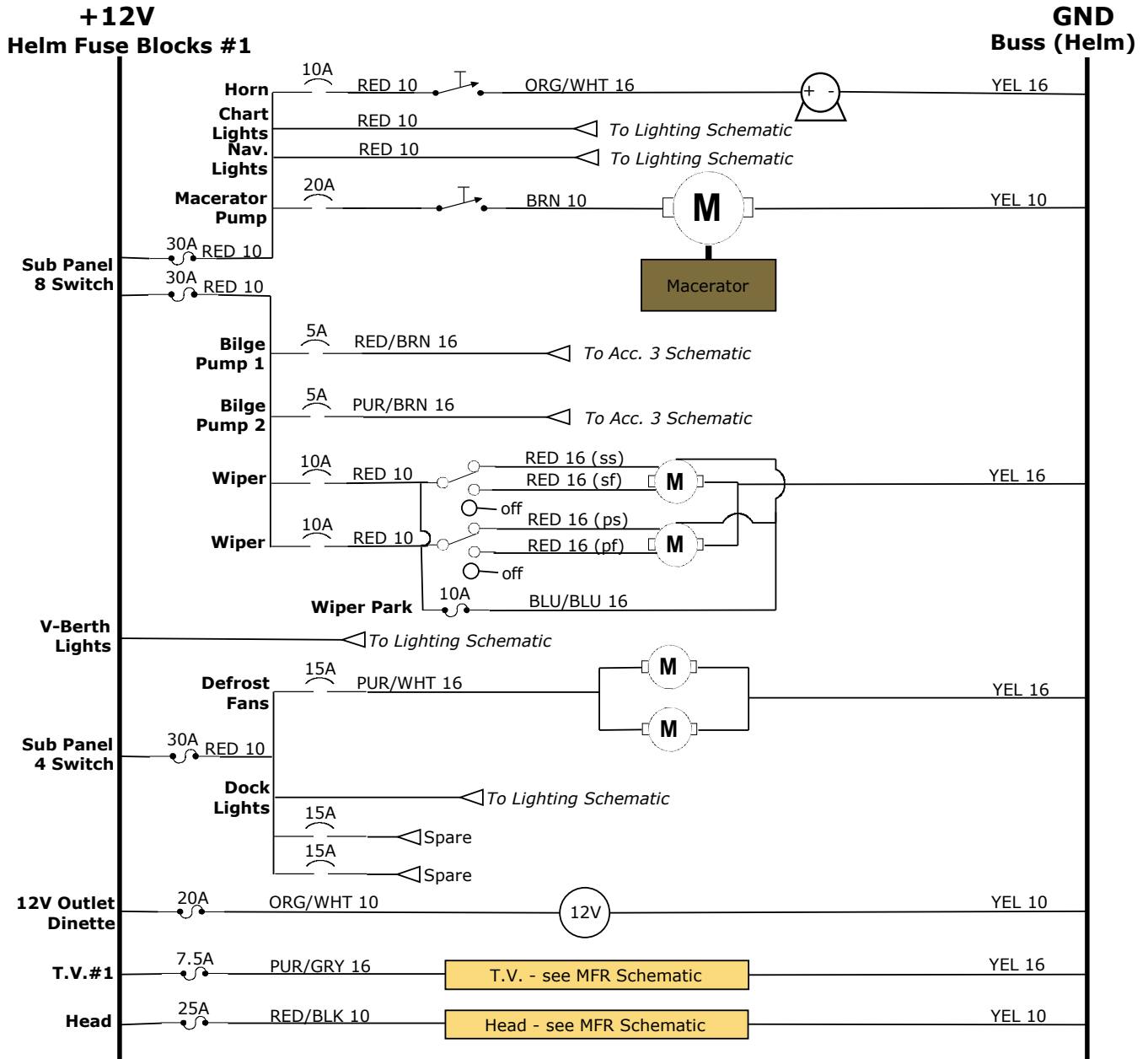

SYMBOL KEY

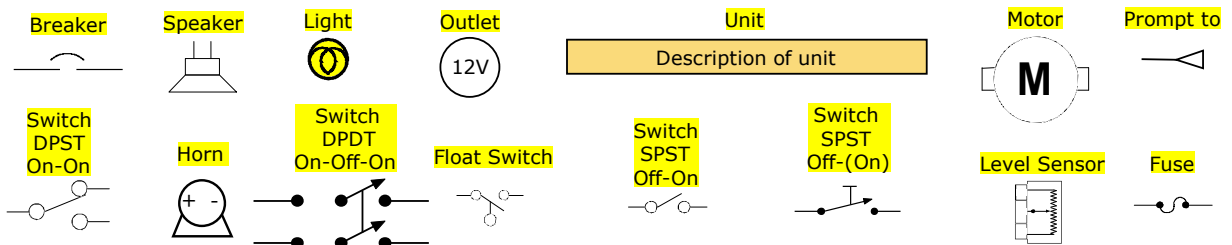

CUTWATER 26 WIRING SCHEMATIC (ACC. 2)

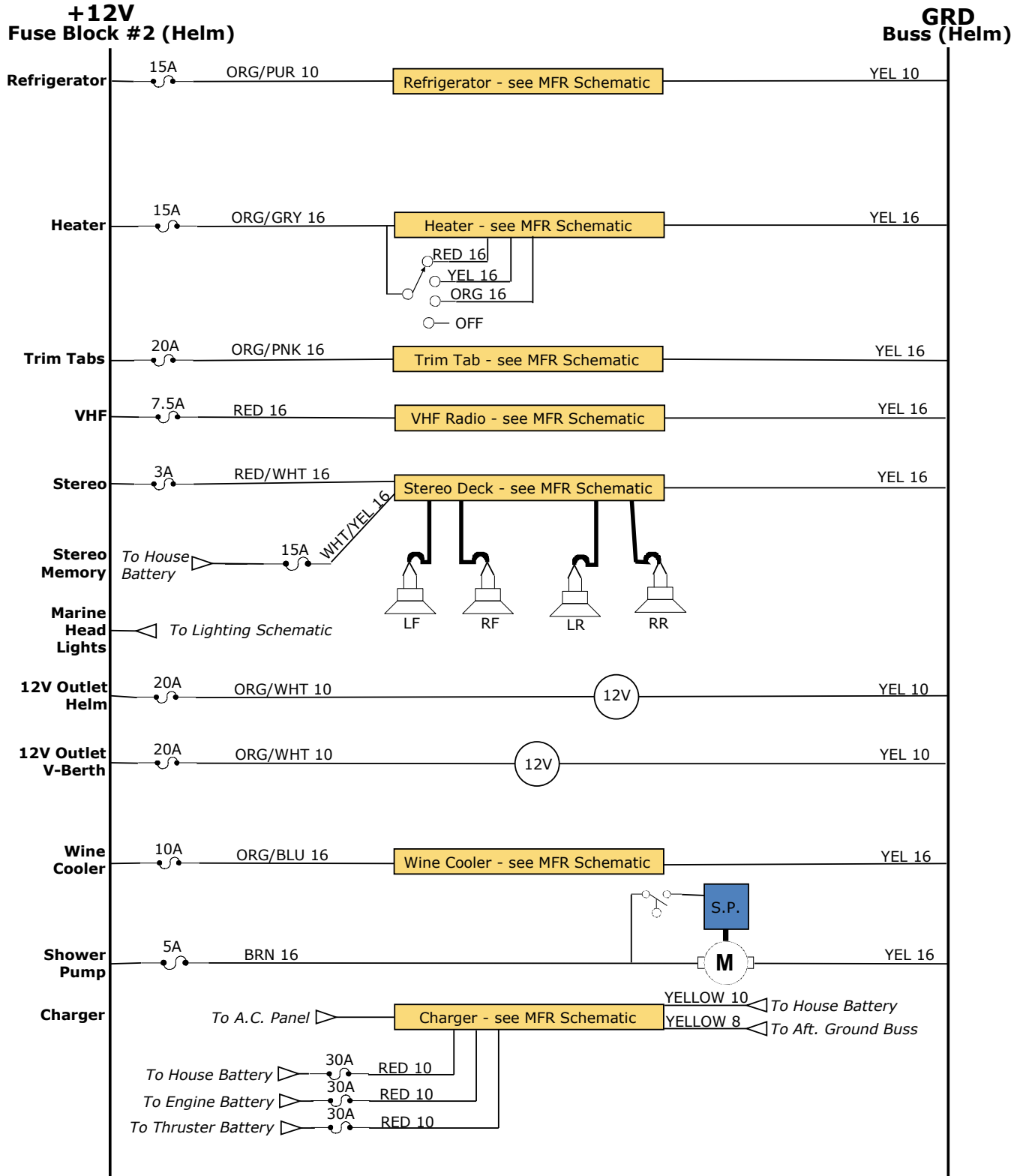

CUTWATER 26 WIRING SCHEMATIC (ACC. 3)

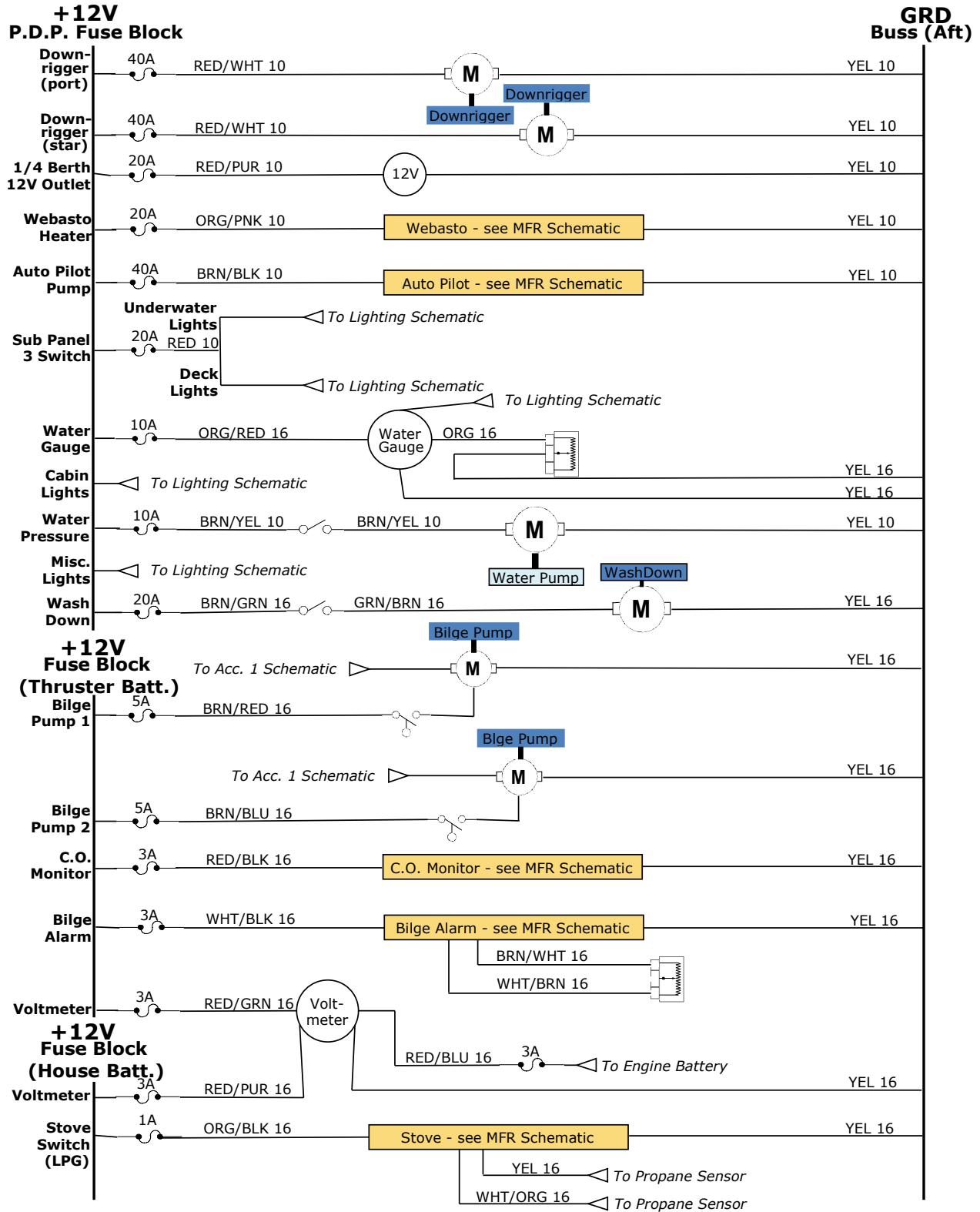

CUTWATER 26 WIRING SCHEMATIC (LIGHTING)

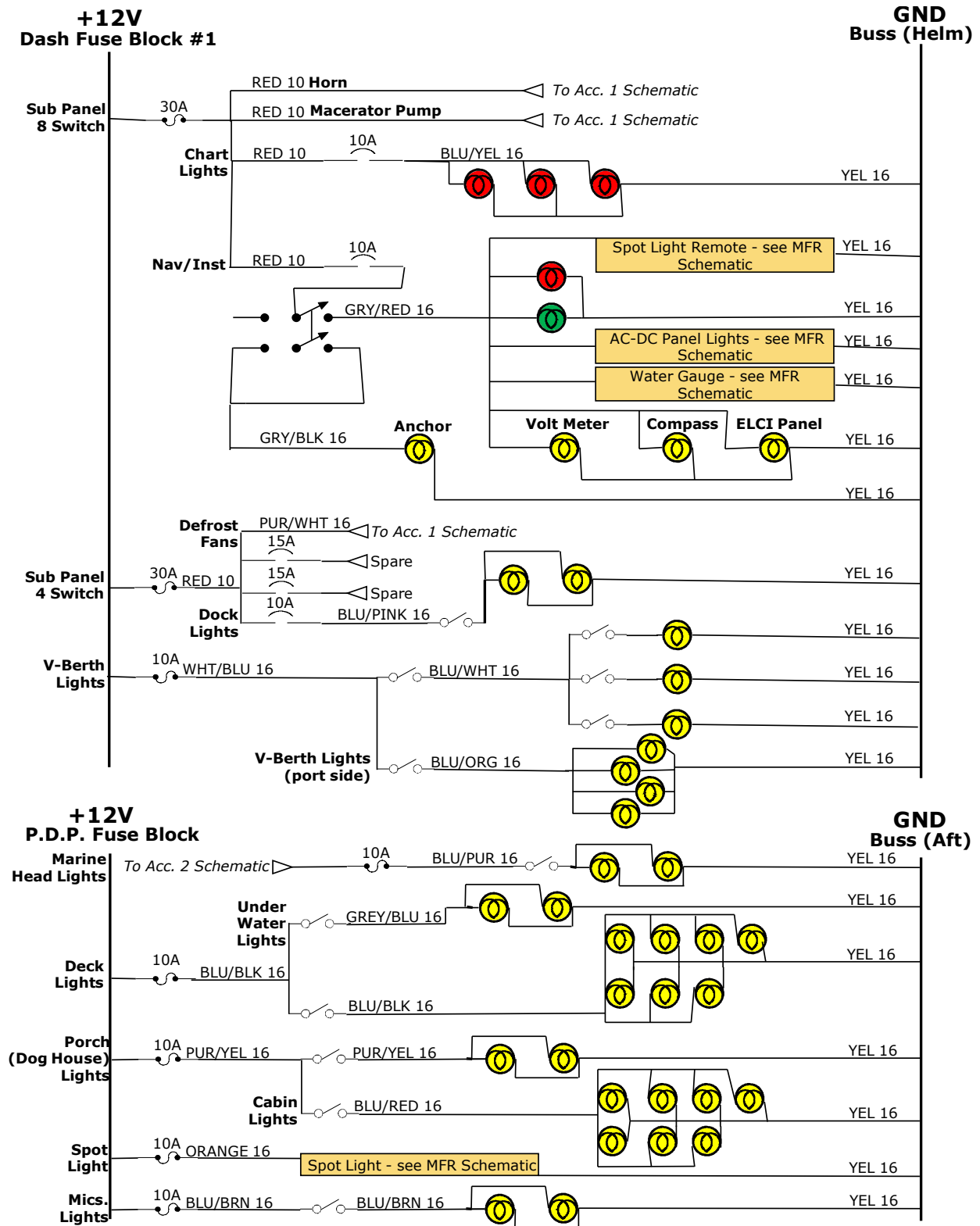

CUTWATER 26 WIRING SCHEMATIC (P.D.P.)

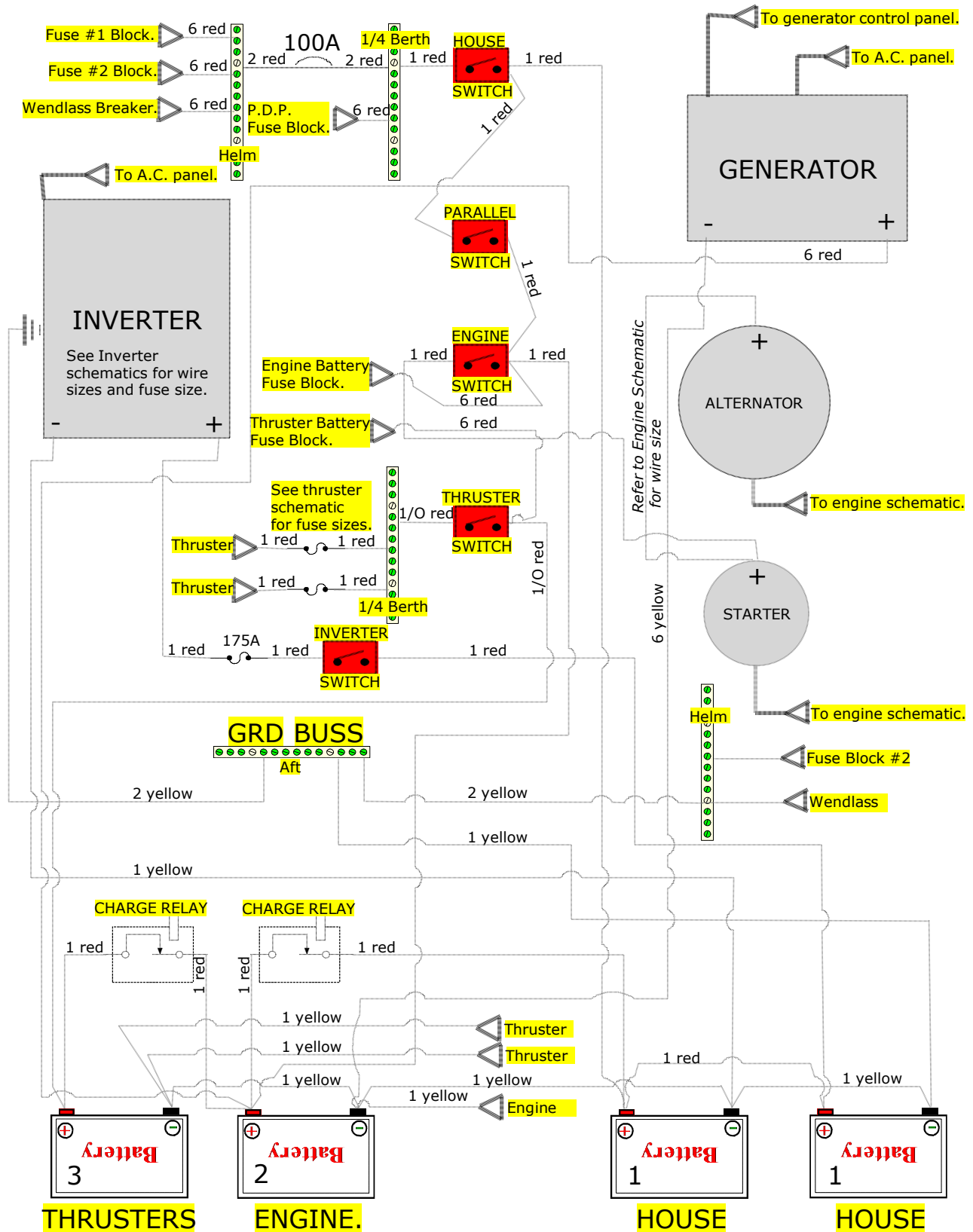

WORKING DECK

STE

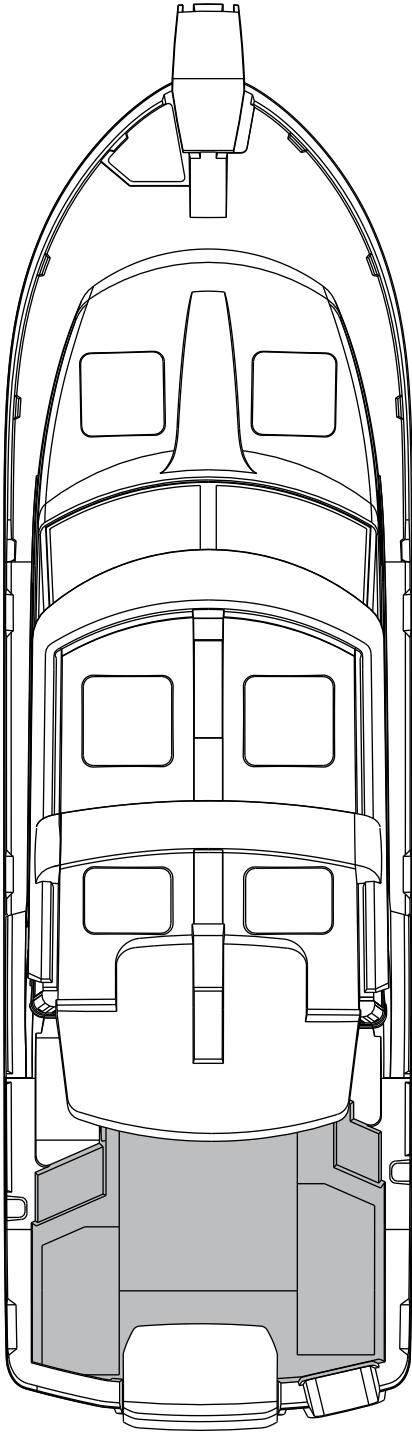

CARE AND MAINTENANCE



The following checklists are examples and are not all inclusive and are provided only as a guide. Please customize to your personal needs. Consult your engine and trailer user manuals for additional information.

EXAMPLE OF A PREPARATION FOR THE ROAD CHECKLIST

TOW VEHICLE – PRIOR TO USE

- Test Lights.
- Check brakes.
- Check tire pressure and condition.
- Check hitch related electrical connections.

TRAILER – PRIOR TO USE

- Check registration
- Check rollers and bed rails.
- Check wheel bearings and lubricate as required.
- Check winch.
- Test electrical connection and lights.
- Check tire pressure and condition.
- Check safety chains.
- Check boat straps.
- Check braking system.
- Check hitch for proper connection and lock down.
- Install safety chains (cross under hitch).
- Remove tire blocks.

BOAT – PRIOR TO USE WITH TRAILER

- Lower mast.
- Lower VHF antenna.
- Secure the Bimini awning frame.
- Raise and secure swim platform ladder.
- Set all switches and breakers to the OFF position, Including Thruster/Windlass cutoff switch
- Close and secure all windows, ports and vents.
- Lock cabin.
- Center rudder.
- Remove Drain Plug

EXAMPLE OF A SPRING PRE-LAUNCH CHECKLIST

CLEANING

- Remove debris from scuppers and scupper drains.
- Clean hull using a mild biodegradable detergent and then wax.
- Clean topsides and decks using a mild biodegradable detergent and then wax.
- Clean and polish all bright work.
- Clean and oil teak.
- Clean windows, ports, and hatches.
- Clean bimini cover.
- Check and clean anchor, rode, and anchor storage compartment.

INSPECTION

- 
- Check Drain Plug
 - Check spare parts and tools and replace as necessary.
 - Check wiper blades.
 - Check swim platform.
 - Inspect and test trim tabs.
 - Check condition of bottom paint.
 - Check windlass.
 - Verify electronics for correct operation.
 - Check all inside and outside lights.
 - Macerator Y-Valve in proper position and secured.
 - Inspect and verify position of all sea cocks and shut off valves.
 - Check alarms for proper operation.
 - Check fluid levels.

SAFETY EQUIPMENT

- Sound signaling device.
- Check flares and their expiration dates.
- Check personal flotation devices.
- Check fire extinguishers and their fill dates.
- First aid kits.

GALLEY

- Check stove for proper operation.
- Check everyday utensil stock.

DOCUMENTS

- Registration sticker.
- Insurance papers and Passports.
- Boat Inspection sticker.
- Charts and float plan forms.

EXAMPLE OF WINTER STORAGE CHECKLIST

GENERAL MAINTENANCE

- Fill Fuel Tank and add a fuel stabilizer.
- Empty and clean black water tank.
- Empty fresh water tank use a non-toxic antifreeze per manufacturer's directions.
- Winterize black and fresh water tanks as necessary based on weather.
- Check bilge area for oil and for proper operation
- Check zincs and replace as necessary.
- Check impeller.
- Check and clean water strainer.
- Clear barnacles and debris from hull fittings.
- Trickle charge batteries every 30-60 days.
- Vent boat to prevent mildew.
- Check trailer tire pressure and condition.
- Check trailer braking system.
- Check trailer bearings.
- Remove Drain Plug.
- Turn off all battery cutoff switches.

ENGINE

- Flush sea strainer system with fresh water.
- Check all fluid levels.
- Check all hose fittings.
- Check engine maintenance requirements.
- Inspect and verify position of all sea cocks and shut off valves.

GALLEY

- Empty, clean and freshen refrigerator.
- Remove all dry food from storage.

REFERENCE MATERIAL

The following table contains a list of reference materials provided by Cutwater that are contained under separate manuals.

| EQUIPMENT | ORIGINAL MANUFACTURER |
|--------------------------|----------------------------------------|
| Navigation System | Garmin |
| Engine C28 | Volvo D4 260 H.P., gear model D4-ZF 63 |
| Engine C26 | Volvo D3 220 H.P., gear model D3-ZF 15 |
| Furnace, diesel | Webasto |
| Trim Tabs | Bennett |
| Thrusters | Side Power |
| Search Light | ITT |
| Raw Water Wash Down | Johnson Pump |
| Water Pump | Johnson Pump |
| Heater | Heater Craft |
| Water Heater | Seaward Products |
| Refrigerator | Nova Kool |
| Y-Valve | Jabsco |
| Compass | Ritchie |
| Power Cord | Furion |
| Kitchen Faucet | ITC |
| Head Faucet | ITC |
| Sea Strainer | Marine Hardware |
| Battery Charger/Inverter | (Pro Mariner) |
| AC Rotary Switch | Blue Sea |
| AC Distribution Panel | Blue Sea |
| DC Distribution Panel | Blue Sea |
| Steering System | Ultraflex |
| Windlass | Lewmar |
| Generator | Mase 2.7kw |

CONTACTS

Customer Service

Andrew Custis Customer Service Manager

Phone 253-839-5213

andrewcustis@cutwaterboats.com

Web Site

www.Cutwaterboats.com

All rights reserved. Reproduction or translation by any means in whole or in part is not permitted without written authorization from Cutwater. The information contained herein is correct to the best of Cutwater knowledge and the contents may change without notice and without incurring obligation.



Phone 253.839.5213

Fax 253.839.5218

cutwaterboats.com

17300 Tye St. S.E
Monroe, Washington 98272